

CITY OF WESTMINSTER			
PLANNING APPLICATIONS SUB COMMITTEE	Date 10 July 2018	Classification For General Release	
Report of Director of Planning		Ward(s) involved St James's	
Subject of Report	Development Site At, 5-9 Great Newport Street, London, WC2H 7JA,		
Proposal	Variation of conditions 1 and 36 of planning permission and condition 1 of listed building consent dated 29 April 2016 (RN: 12/03930/FULL and 12/03931/LBC) for 'Demolition of Nos. 6-9 Great Newport Street behind retained front facades and demolition of rear addition to No. 5 Great Newport Street. Excavation and redevelopment to provide a building comprised of lower basement, basement, lower ground, ground and six upper floors, terraces, roof plant and alterations to front facade, providing a new auditorium and ancillary services in the form of a new flexible theatre space and arts club venue along with rehearsal studio and ancillary facilities including bars at basement level 1 and ground floor level (sui generis), restaurant (Class A3) on the ground floor and part lower ground floors and a hotel at part ground and first to sixth floor levels (across 5-9 Great Newport Street), associated hotel bar and sculpture gallery at first floor level and outdoor swimming pool, terrace and bar at fifth floor level'. Namely, to allow amendments to the consented scheme including increase the theatre capacity to over 400 seats, intensification of the hotel use from 66 rooms to 155 rooms, provide 24 cycle parking spaces, fenestration changes to rear elevation including new windows, increase the height and amount of plant within the rooftop plant enclosure, alterations to ground floor level shopfronts, creation of lightwell enclosed by railings outside 6 - 7 Great Newport Street, and internal alterations.		
Agent	Iceni Projects		
On behalf of	Consolidated St Giles LLP		
Registered Number	18/01160/FULL	Date amended/ completed	14 February 2018
Date Application Received	9 February 2018		
Historic Building Grade	Grade II		
Conservation Area	Covent Garden		

1. RECOMMENDATION

1. Grant conditional permission subject to the completion of a deed of variation of the legal agreement dated 29 April 2016 to secure the following:

- a) The provision of a replacement theatre fitted out to shell and core prior to the occupation of the hotel and restaurant.
- b) The placing of £600,000 (index linked) into an escrow account to be released to a theatre operator to fund the fit out of the theatre.
- c) To secure the Theatre space to be operated by 'PW (Peter Wilson) Productions Ltd' or another theatre operator with West End experience proposed by the Developer and approved by the Council

or a theatre operator determined by a senior representative from the Theatres Trust to have West End experience.

d) The theatre space to be used for theatrical performances on at least 320 days a year (further details within the legal agreement).

e) To ensure the link between the theatre and restaurant is open before, during and after performances.

f) The provision and retention of a publicly accessible curated sculpture gallery within the hotel.

g) The applicant to comply with the Council's Code of Construction Practice, provide a Site Environmental Management Plan prior to commencement of development and provide a financial contribution of £80,000 per annum during demolition and construction to fund the Environmental Inspectorate and monitoring by Environmental Sciences officers.

h) s106 monitoring costs.

2. If the deed of variation to the S106 legal agreement dated 29 April 2016 has not been completed within 6 weeks of the date of this resolution then:

a) The Director of Planning shall consider whether it would be possible and appropriate to issue the permission with additional conditions attached to secure the benefits listed above. If so, the Director of Planning is authorised to determine and issue such a decision under Delegated Powers; however, if not;

b) The Director of Planning shall consider whether permission should be refused on the grounds that the proposals are unacceptable in the absence of the benefits which would have been secured; if so, the Director of Planning is authorised to determine the application and agree appropriate reasons for refusal under Delegated Powers.

3. Grant conditional listed building consent.

4. Agree the reasons for granting listed building consent as set out in informative 1 of the draft decision letter.

2. SUMMARY

The application site is comprised of a row of buildings between 5 and 9 Great Newport Street. No. 5 is Grade II listed and the entire site lies within the Covent Garden Conservation Area the Core Central Activities Zone and the West End Stress Area. The buildings on the site range from between four and six storeys with basements, and they contain a variety of uses including the Arts Theatre Club (sui generis), the former site of the 'Photographers Gallery' (Class D1), restaurant/bar (mixed A3 and A4), offices and a language school.

An application was reported to Planning Applications Committee on 12 April 2016 (following its initial deferral on 13 May 2014). Committee resolved to grant planning permission and listed building consent and the decision was issued on 29 April 2016 (RNs: 12/03930/FULL and 12/03931/LBC) for:

"Demolition of Nos 6-9 Great Newport Street behind retained front facades and demolition of rear addition to No. 5 Great Newport Street. Excavation and redevelopment to provide a building comprised of lower basement, basement, lower ground, ground and six upper floors, terraces, roof plant and alterations to the front façade, providing a new auditorium and ancillary services in the form of a new flexible theatre space and arts club venue along with rehearsal studio and ancillary facilities including bars at basement level 1 and ground floor level (sui generis), restaurant (Class A3) on the ground floor and part lower ground floors and a 66 bedroom hotel at part ground and first to sixth floor levels (across 5-9 Great 2 Newport Street), associated hotel bar and sculpture gallery at first floor level and outdoor swimming pool, terrace and bar at fifth floor level."

This latest application has been submitted under Section 73 of the Town and Country Planning Act and seeks to vary of Conditions 1 and 36 of the planning permission and condition 1 of the listed

building consent dated 29 April 2016 (RNs: 12/03930/FULL and 12/03931/LBC) to allow amendments to the approved development.

The amendments to the approved development, for which permission is now sought, are:

- (a) To increase the theatre capacity to over 400 seats (in line with condition 36);
- (b) Intensification of the hotel use within the approved building envelope from 66 rooms to 155 rooms;
- (c) Provision of 24 cycle parking spaces;
- (d) Alterations to the rear fenestration including new windows;
- (e) Increase the height and amount of plant within the rooftop plant enclosure;
- (f) Alterations to ground floor level shopfronts;
- (g) Lightwell enclosed by railings outside 6 - 7 Great Newport Street; and
- (h) Internal alterations to layouts of theatre, hotel and restaurant.

The key issues for consideration are:

- The land use implications of the proposals;
- The impact of the proposed works on the character and appearance of the building and surrounding conservation area;
- The impact of the proposal on the amenity of surrounding residents; and
- The impact of the proposal on the surrounding highway network.

Land Use

Increased theatre capacity: Condition 36 of the approved development requires the submission of revised layout plans to increase the seating capacity of the theatre to approximately 400 seats. The increase in theatre capacity from 360 to 400 seats is welcomed and is supported by the proposed operator 'PW (Peter Wilson) Productions Ltd'. The Theatres Trust are also generally supportive of the amendments but raise a number of concerns relating to Fire safety and evacuation; Managing performance cross-over; Ceiling heights; Fit-out and ongoing costs; Get-in; Public entry; Part M compliance; and the Theatre operator. The applicant has sought to alleviate the Theatre Trust's concerns. To ensure that the theatre is provided, the application is subject to a legal agreement, which sets out when the phases of the redevelopment need to be carried out by, how these costs are borne out, and also confirmation of the theatre operator 'PW (Peter Wilson) Productions Ltd'.

Intensification of hotel from 66 rooms to 155 rooms: The applicant advises that they have held discussions with potential operators (Citizen M, Z Hotels, and 25 Hours) who have expressed an interest in intensifying the room numbers to make the hotel more viable and usable, and provide a hotel based on 'pod' type rooms. These operators target the tourist or business visitor to London who prefer a low cost room to sleep in for shorter length of stay, preferring to use the various facilities and attractions within walking distance of the hotel.

Objections have been received on grounds the intensification of the hotel use from 66 rooms to 155 rooms would increase the number of people coming and going, as well as increase the volume of servicing and deliveries.

The additional hotel rooms would result in an increased amount of waste and servicing requirements. The applicant has submitted a Servicing Management Plan but this has limited detail. The servicing process will need to be carefully managed given the increased activity the hotel will generate. Detail on how the arrival of vehicles will be managed is required, to ensure congestion is not exacerbated by numerous servicing vehicles arriving at similar times. It is considered that this could be dealt with a detailed and robust Servicing Management Plan.

Given the increase in capacity of the hotel, the Highways Planning Manager is concerned that the hotel makes no provision for coaches. A condition is recommended to restrict the hotel from accepting bookings from coach parties.

The hotel of the scale proposed is considered appropriate in this central area of Westminster, and is unlikely to cause an adverse impact on residential amenity subject to conditions, which also include controlling the roof terrace, and bar areas and opening hours to non-hotel residents.

Townscape and Design

Alterations to the rear fenestration: The works propose to alter the appearance of the approved rear elevation, through the insertion of a number of windows. This elevation was previously rather blank and indicated its then, service nature. The insertion of windows as part of the additional hotel rooms will add interest to the elevation and are considered acceptable in design terms. Conditions are recommended to ensure that details of the windows are submitted.

Increase in Height: The works seek to increase the height and amount of plant within the approved plant enclosure. The enclosure is to be increased in height by a nominal amount (approx. 250mm) and is to increase in size, moving hard up the rear elevation and stretching further forward towards the front elevation. The additional space is required to accommodate the rearranged and additional rooftop mechanical plant. Given the minimal increase in height and that the position is not visible from the street level. The increase is not considered harmful, although it is noted that this is the limit of the size and massing that would be considered acceptable at roof level.

Alterations to ground floor level shopfronts: The proposed alterations to the shopfronts are minimal and not considered to harm the character of the building or conservation area.

Lightwell enclosed by railings outside 6 - 7 Great Newport Street: The works include the retention and alteration of the existing light well, which was to be removed as part of the original development. The removal of the light well was considered a benefit to the scheme and it is therefore disappointing that it is to be retained. However, given that it is an existing feature its removal cannot be enforced. The light well is to be enclosed by railings located outside of 6 - 7 Great Newport Street, which is considered a suitable boundary treatment. Conditions should ensure that details of the railings are submitted.

Internal alterations: The new hotel bedrooms on the upper floors are set back from the front façade as shown in both the section and the plan by a glazed internal wall. This set back will visually separate the existing facade from the proposed internal rooms. The glazed internal wall of the hotel bedrooms would still allow for activity to be viewed behind the front facade windows and as such this is not considered to harm the appearance of this building or conservation area.

Amenity

Objections have been received on grounds the amended development would adversely harm the amenity of neighbouring occupiers in terms of loss of light, increased sense of enclosure and overlooking of neighbouring properties, in particular Sandringham Flats.

The works seek to increase the height of the approved rooftop plant enclosure by approx 250mm as well as insert windows in the rear elevation for the additional hotel bedrooms. Given the significant distance between the application site and windows in Sandringham Flats, circa 40 metres, it is not considered that the development would result in any unacceptable loss of light, increased sense of enclosure or overlooking to these properties.

The works seek to increase the amount of plant within the approved plant enclosure at roof level. Conditions are recommended to secure full details and a supplementary acoustic report when plant has been selected, to confirm compliance with the Council's standard noise condition.

Objections have also been received concerned with the structural implications of the proposals. The application is supported by a Structural Engineering Report, which demonstrates that is intended for the proposals to progress structurally as originally intended and permitted. The report has been assessed by Building Control who has advised that the proposed structural approach appears satisfactory. The City Council is not approving this report or conditioning that the works shall

necessarily be carried out in accordance with the report. Its purpose is to show, with the integral professional duty of care, that there is no reasonable impediment foreseeable at this stage to the scheme satisfying the Building Regulations in due course.

The proposed amendments are considered to be acceptable in land use, design, amenity, transportation and environment terms and would accord with the relevant policies, including those policies that have been adopted since the determination of the previous applications in April 2016, in the Unitary Development Plan adopted in January 2007 (the UDP) and Westminster's City Plan adopted in November 2016 (the City Plan). It is therefore recommended that planning permission and listed building consent is granted, subject to the conditions set out in the draft decision letters appended to this report.

3. LOCATION PLAN

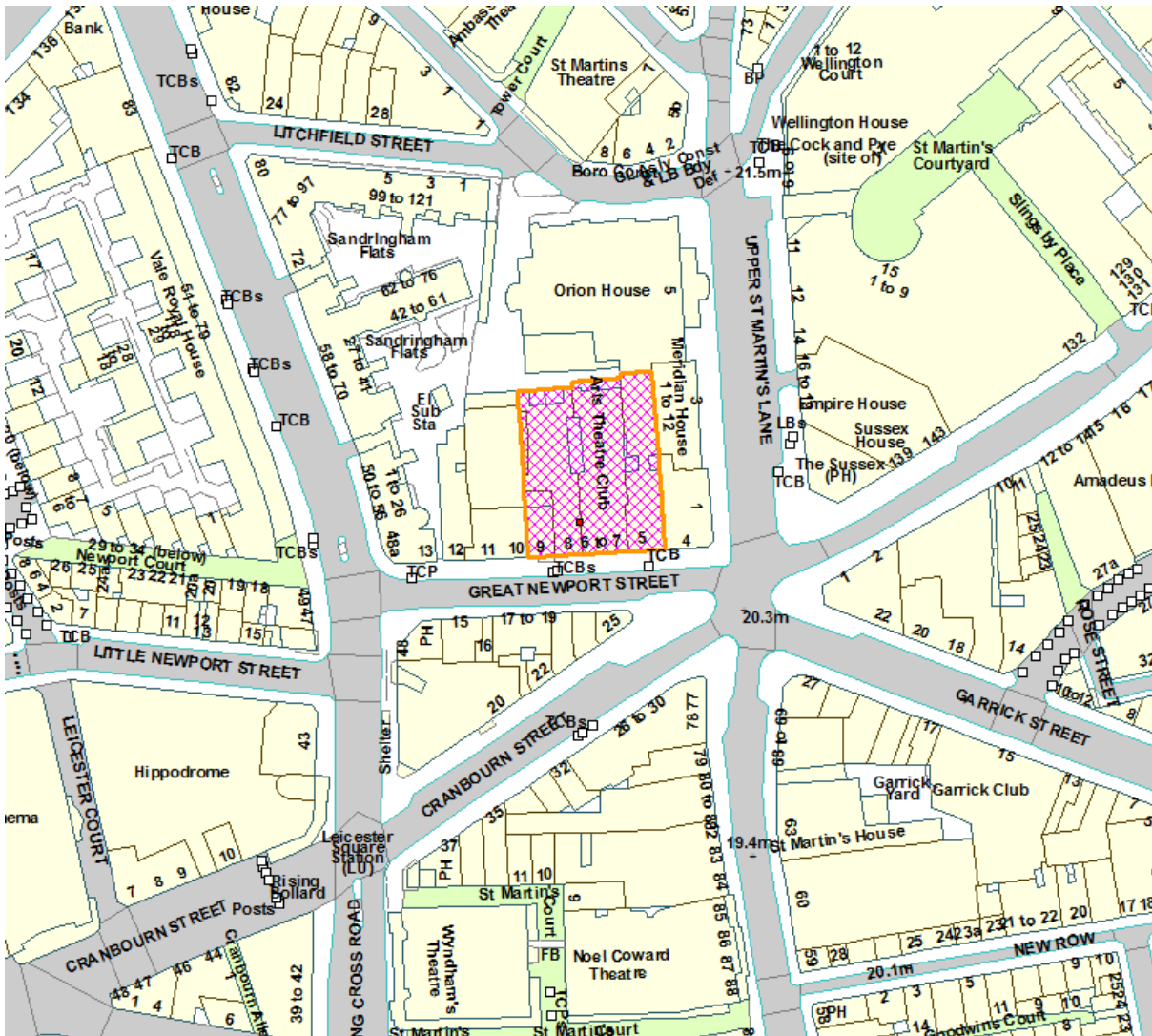

This production includes mapping data licensed from Ordnance Survey with the permission of the controller of Her Majesty's Stationary Office (C) Crown Copyright and /or database rights 2013. All rights reserved License Number LA 100019597

4. PHOTOGRAPHS



5-9 Great Newport Street, London, WC2H 7JB

5. CONSULTATIONS

COVENT GARDEN COMMUNITY ASSOCIATION

Do not object to proposals to increase the theatre capacity to 400.

Raise objections and concerns on a number of issues:

- Intensification of the hotel use from 66 rooms to 155 rooms, will increase the number of people coming and going as well as increase services and deliveries;
- Proposals increase height and bulk of the development, which was already out of character with the conservation area;
- Height increase will adversely affect neighbouring properties, which already see their views and light disrupted by the permitted scheme.

COVENT GARDEN AREA TRUST

Any response to be reported verbally.

LONDON BOROUGH OF CAMDEN:

Any response to be reported verbally.

THE THEATRES TRUST

The Trust cautiously supports the theatre aspect of this application subject to a number of concerns being addressed. Concerns relate to Fire safety and evacuation; Managing performance cross-over; Ceiling heights; Fit-out and ongoing costs; Get-in; Public entry; Part M compliance; and the Theatre operator.

HIGHWAYS PLANNING MANAGER:

Raise concerns on a number of issues:

- The highway alterations notably the retention of the front light well is not securing an improved pedestrian environment;
- Servicing will need to be carefully managed;
- No provision for coach party arrivals is provided;
- Further work is required to address management of coaches, taxis, private hire vehicles and servicing - recommends a condition requiring a robust Servicing Management Plan.

BUILDING CONTROL:

The structural method statement is considered to be acceptable.

LONDON UNDERGROUND:

Any response to be reported verbally.

ADJOINING OWNERS/OCCUPIERS AND OTHER REPRESENTATIONS RECEIVED:

No. Consulted: 247

Total No. of replies: 8

No. of objections: 8

Objections received on some or all of the following grounds:

- Risk of structural damage to adjoining buildings;
- Increase in foot fall, servicing, traffic, pollution, noise and disturbance;
- Loss of light and increased sense of enclosure to Sandringham Flats;
- Overlooking of neighbouring properties;
- Lack of engagement from the applicant and planners with local residents.

PRESS ADVERTISEMENT / SITE NOTICE: Yes

6. BACKGROUND INFORMATION

6.1 Recent Relevant History

12/03930/FULL

Demolition of Nos. 6-9 Great Newport Street behind retained front facades and demolition of rear addition to No. 5 Great Newport Street. Excavation and redevelopment to provide a building comprised of lower basement, basement, lower ground, ground and six upper floors, terraces, roof plant and alterations to front facade, providing a new auditorium and ancillary services in the form of a new flexible theatre space and arts club venue along with rehearsal studio and ancillary facilities including bars at basement level 1 and ground floor level (sui generis), restaurant (Class A3) on the ground floor and part lower ground floors and a 66 bedroom hotel at part ground and first to sixth floor levels (across 5-9 Great Newport Street), associated hotel bar and sculpture gallery at first floor level and outdoor swimming pool, terrace and bar at fifth floor level.

Application Permitted 29 April 2016

17/03551/FULL

Variation of condition 26 and 27 of planning permission dated 28 April 2016 (RN: 12/03930/FULL) for the 'demolition of Nos. 6-9 Great Newport Street behind retained front facades and demolition of rear addition to No. 5 Great Newport Street. Excavation and redevelopment to provide a building comprised of lower basement, basement, lower ground, ground and six upper floors, terraces, roof plant and alterations to front facade, providing a new auditorium and ancillary services in the form of a new flexible theatre space and arts club venue along with rehearsal studio and ancillary facilities including bars at basement level 1 and ground floor level (sui generis), restaurant (Class A3) on the ground floor and part lower ground floors and a 66 bedroom hotel at part ground and first to sixth floor levels (across 5-9 Great Newport Street), associated hotel bar and sculpture gallery at first floor level and outdoor swimming pool, terrace and bar at fifth floor level'. Namely, to vary the requirement to attain a BREEAM rating of 'Outstanding' to a BREEAM rating of 'Very Good'.

Application Permitted 4 December 2017

18/01411/NMA

Amendments to planning permission dated 29 April 2016 (RN: 12/03930) for: Demolition of Nos. 6-9 Great Newport Street behind retained front facades and demolition of rear addition to No. 5 Great Newport Street. Excavation and redevelopment to provide a building comprised of lower basement, basement, lower ground, ground and six upper floors, terraces, roof plant and alterations to front facade, providing a new auditorium and ancillary services in the form of a new flexible theatre space and arts club venue along with rehearsal studio and ancillary facilities including bars at basement level 1 and ground floor level (sui generis), restaurant (Class A3) on the ground floor and part lower ground floors and a 66 bedroom hotel at part ground and first to sixth floor levels (across 5-9 Great Newport Street), associated hotel bar and sculpture gallery at first floor level and outdoor swimming pool, terrace and bar at fifth floor level; namely, to amend the description of development to remove reference to the number of hotel rooms.

Application Permitted 22 February 2018

(Please note: All the application drawings and other relevant documents and Background Papers are available to view on the Council's website)

IF YOU HAVE ANY QUERIES ABOUT THIS REPORT PLEASE CONTACT THE PRESENTING OFFICER: DAVID DORWARD BY EMAIL AT ddorward@westminster.gov.uk

7. KEY DRAWINGS

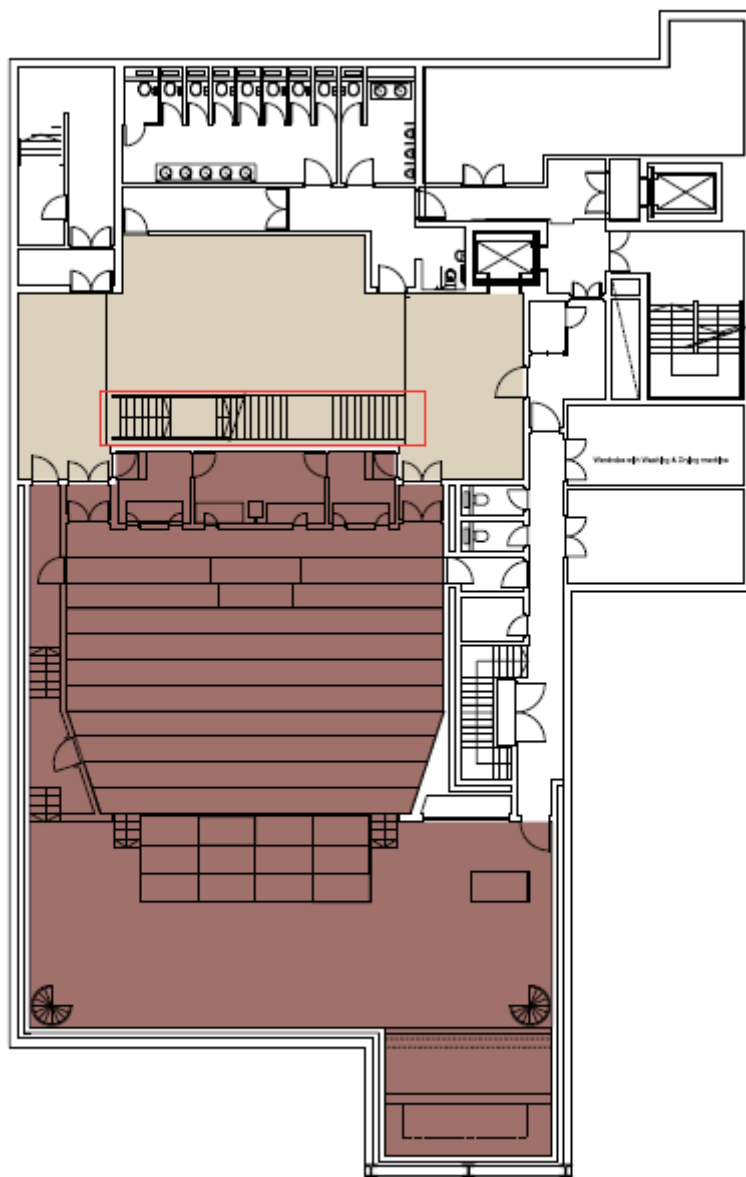

CONSENTED Theatre layout

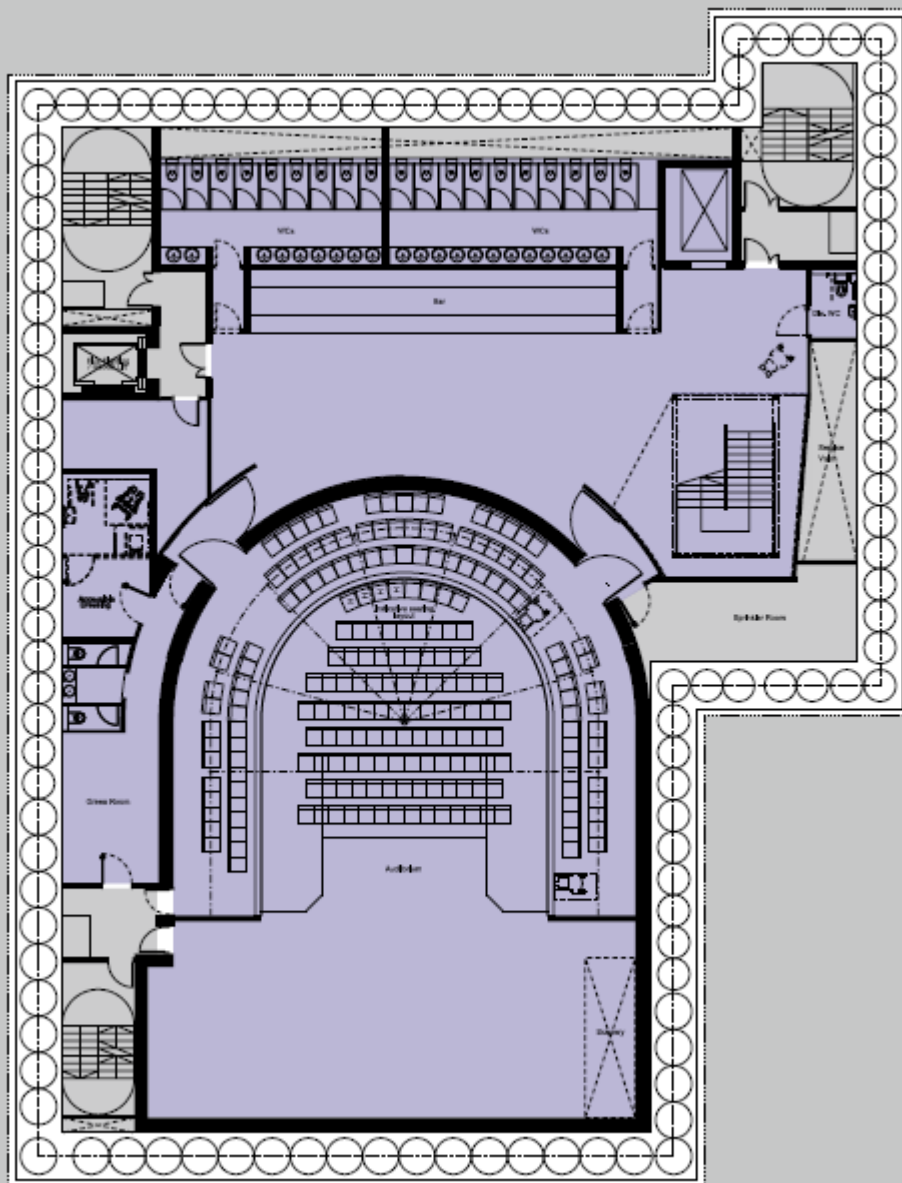

PROPOSED Theatre layout

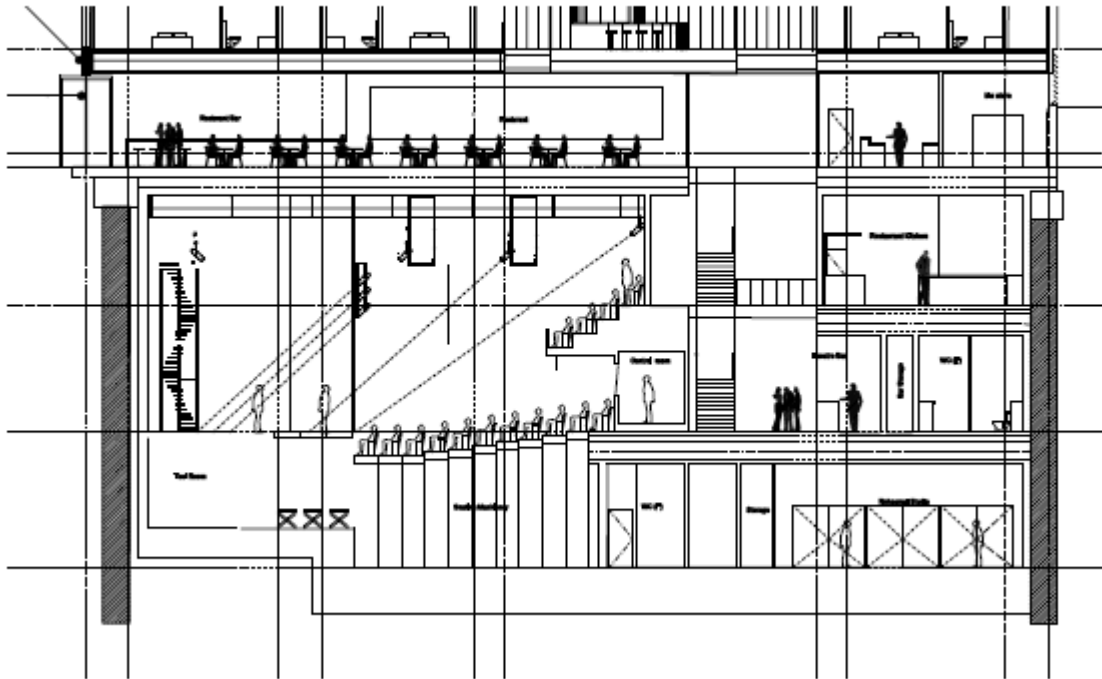

CONSENTED Theatre section

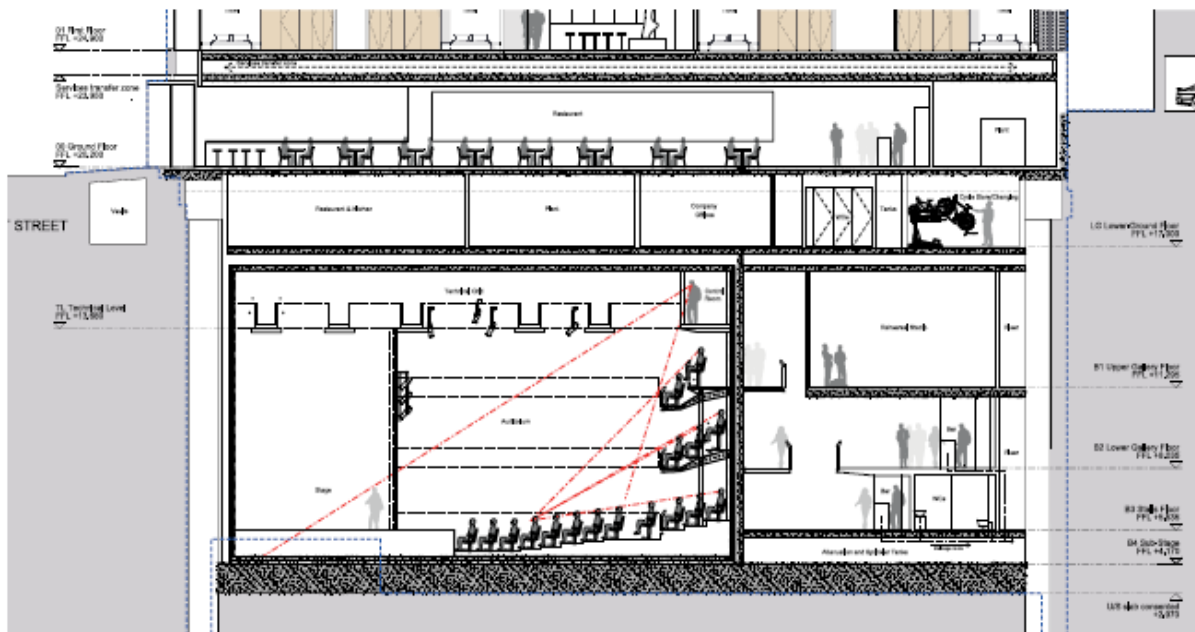

PROPOSED Theatre section

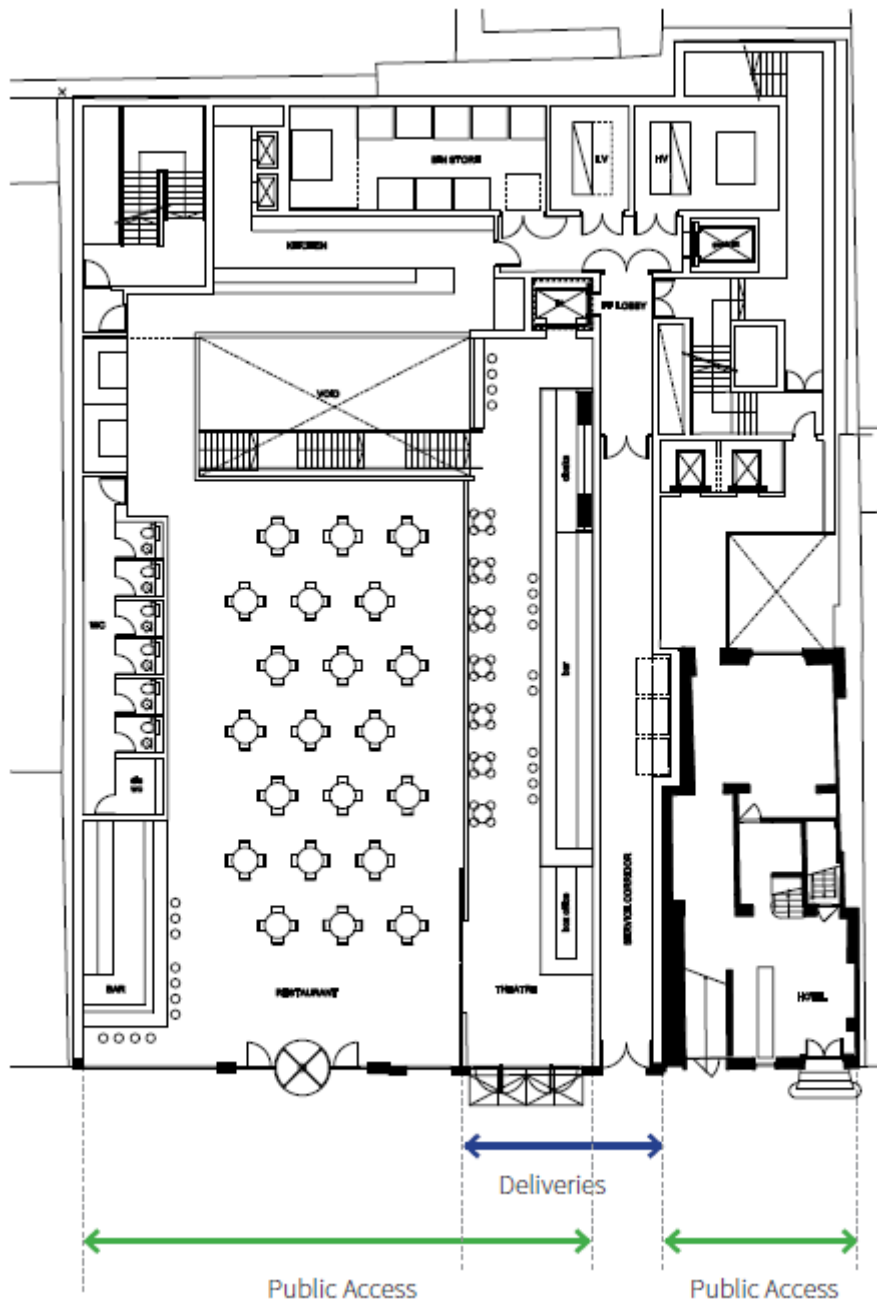

CONSENTED Ground floor

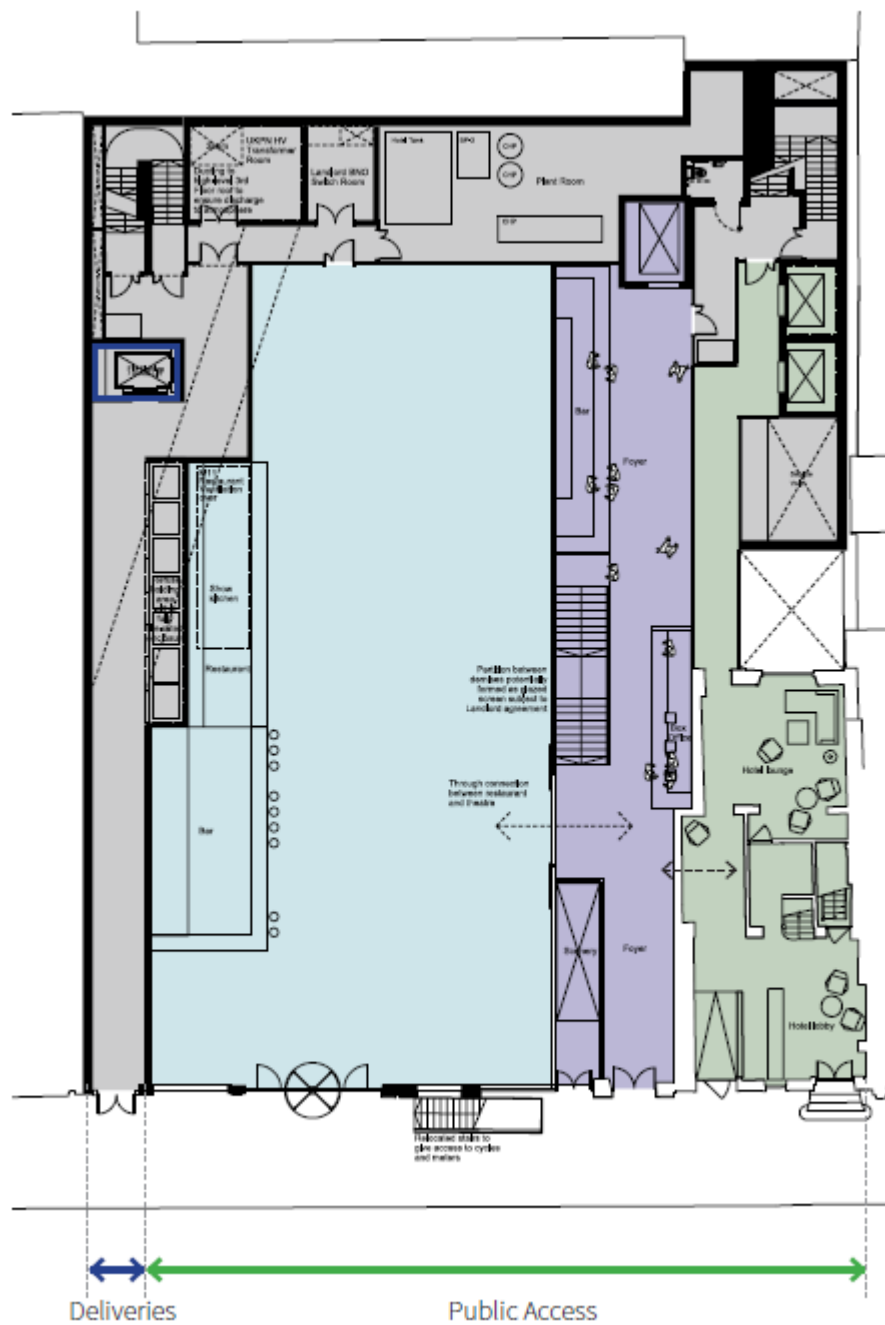

PROPOSED Ground floor

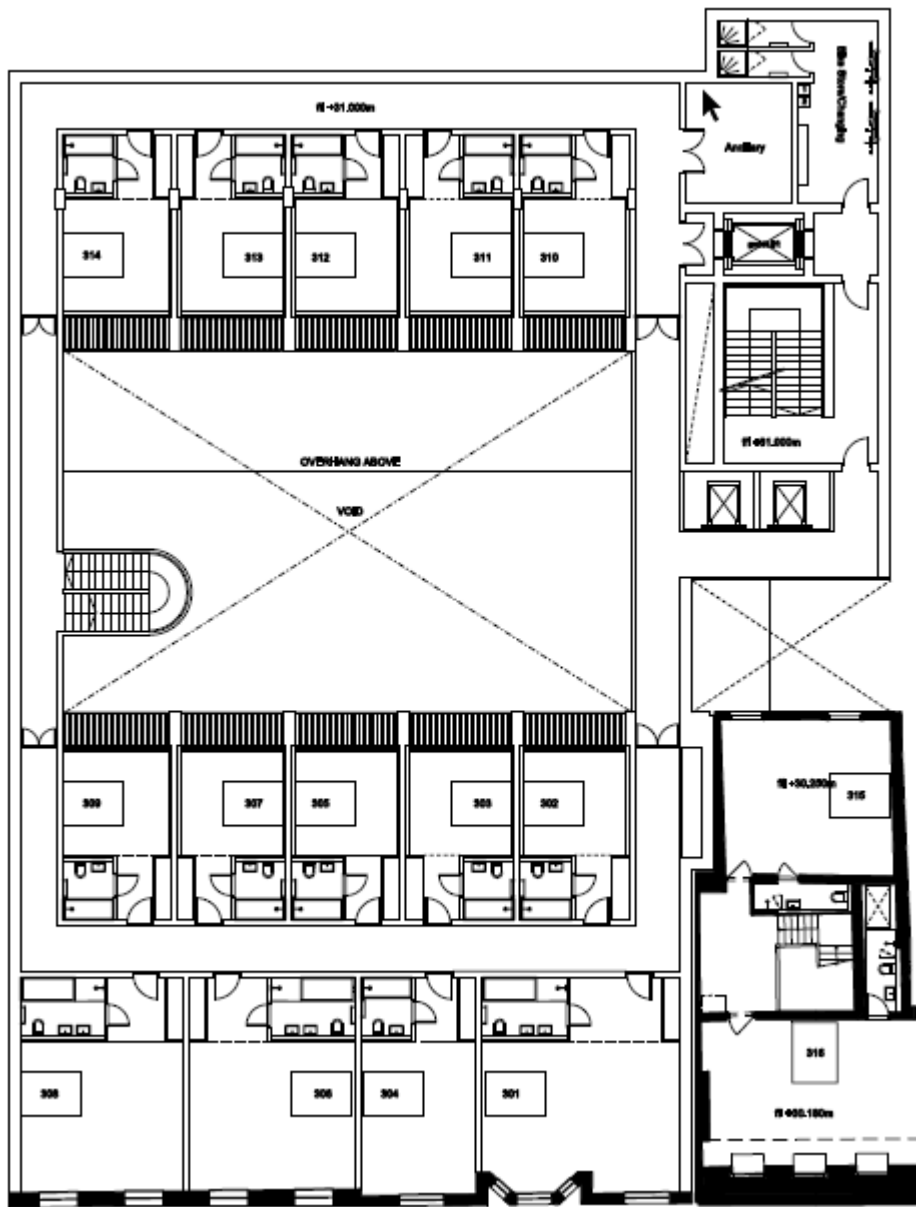

CONSENTED Hotel layout (second floor)

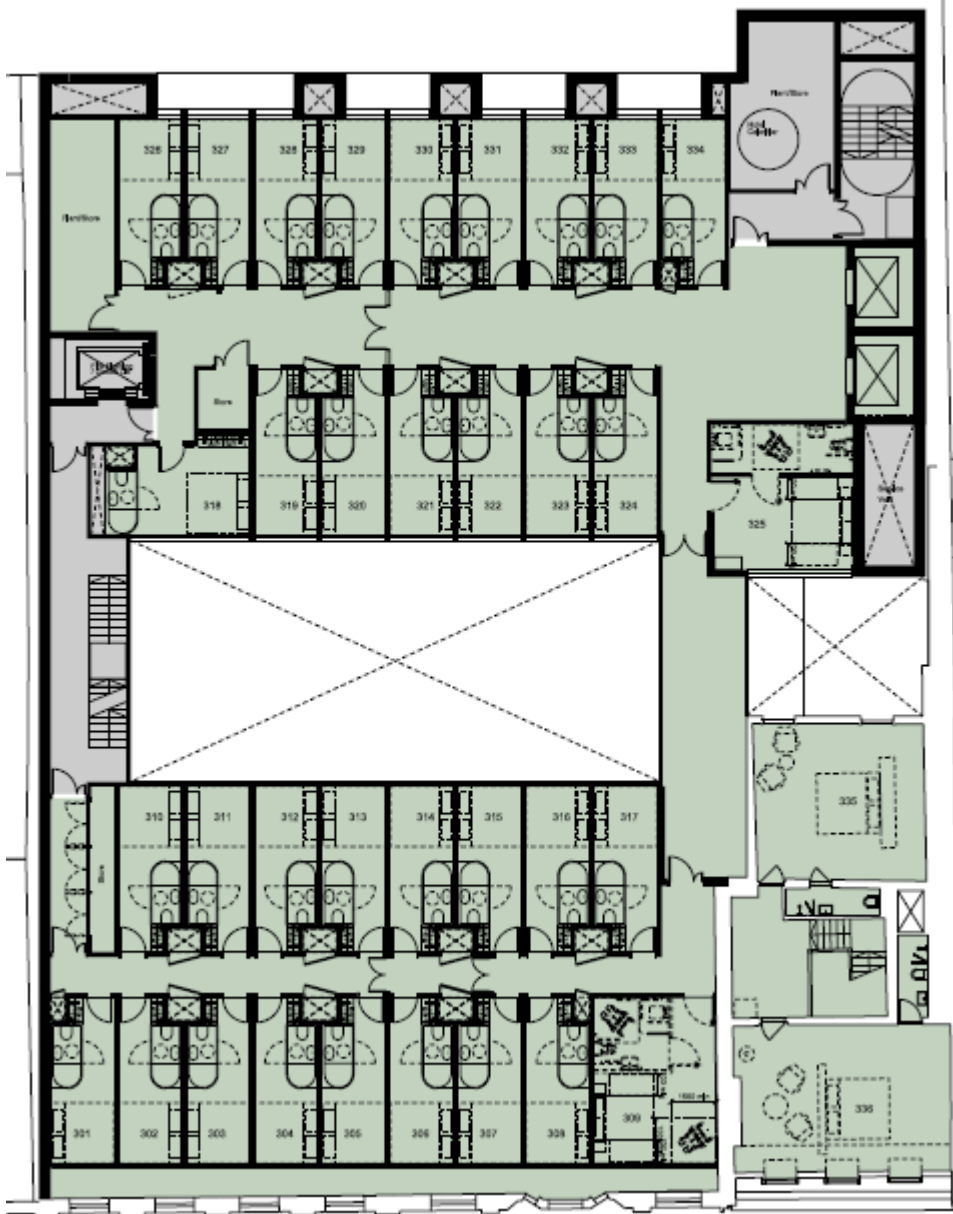

PROPOSED Hotel layout (second floor)

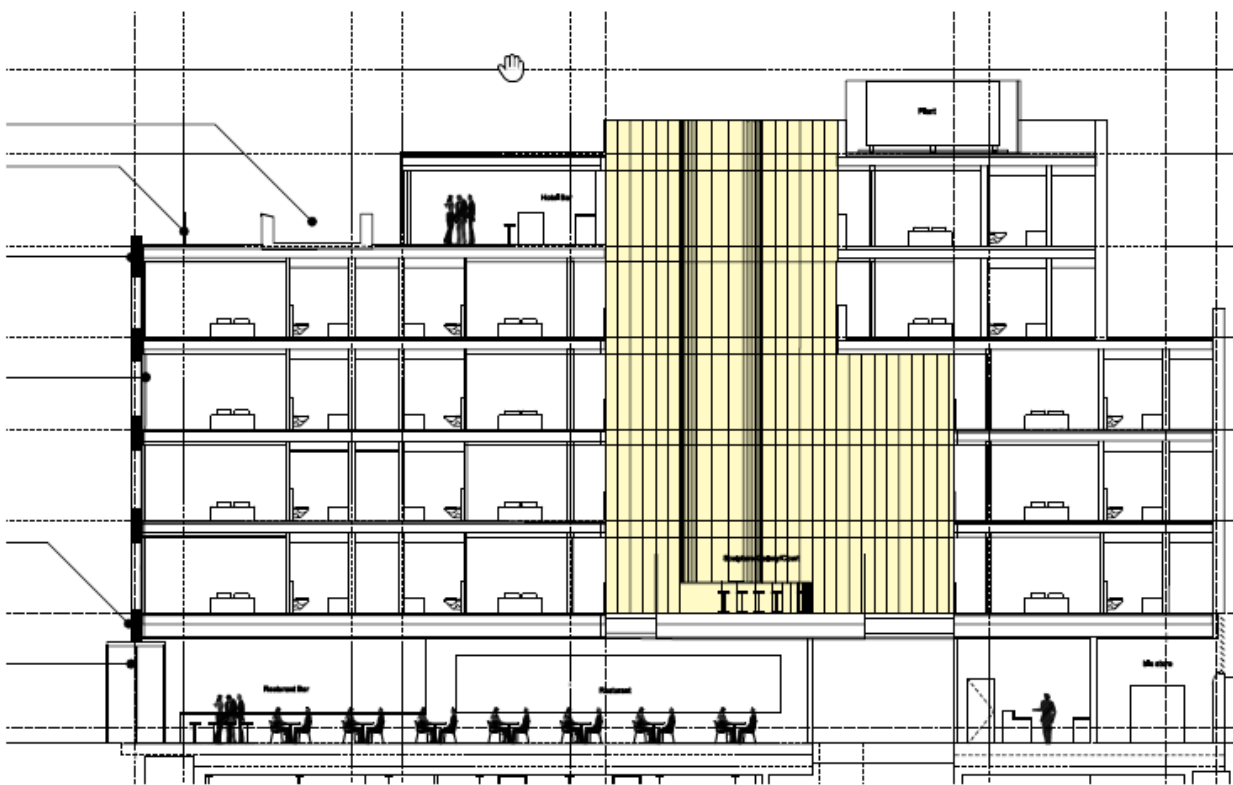

CONSENTED Hotel Atrium

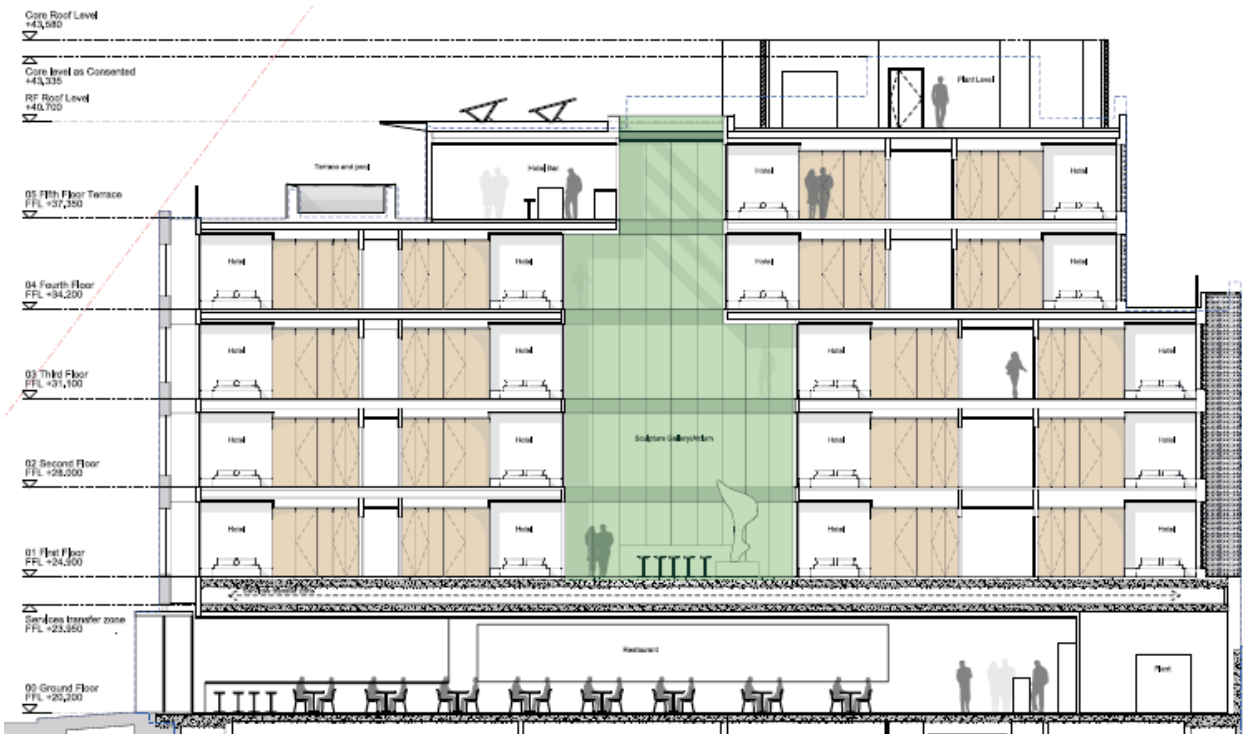

PROPOSED Hotel Atrium



CONSENTED Front elevation

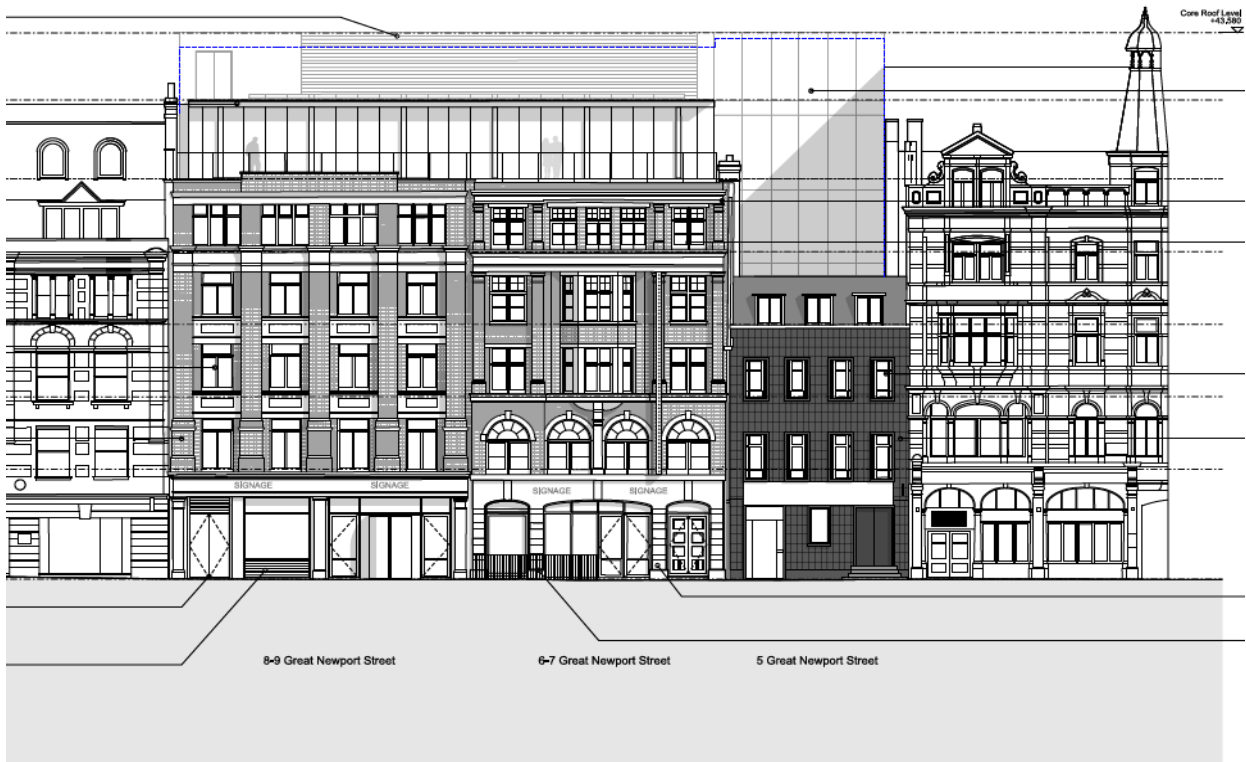

PROPOSED Front elevation

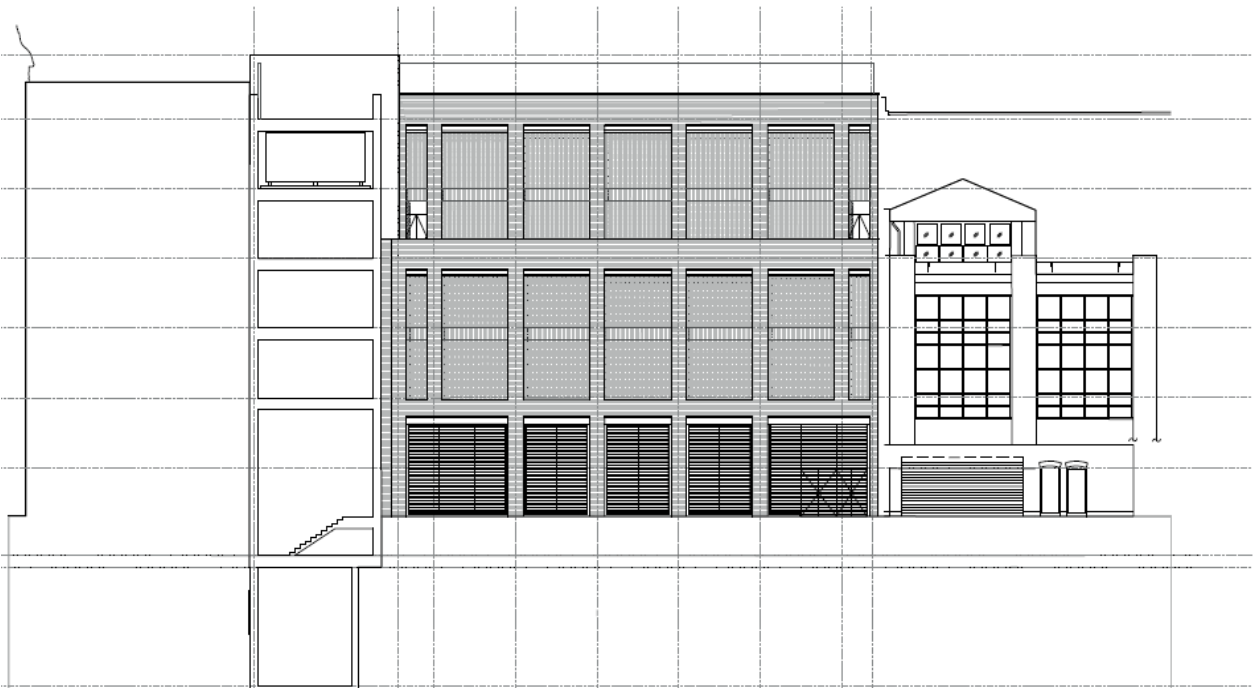

CONSENTED Rear elevation

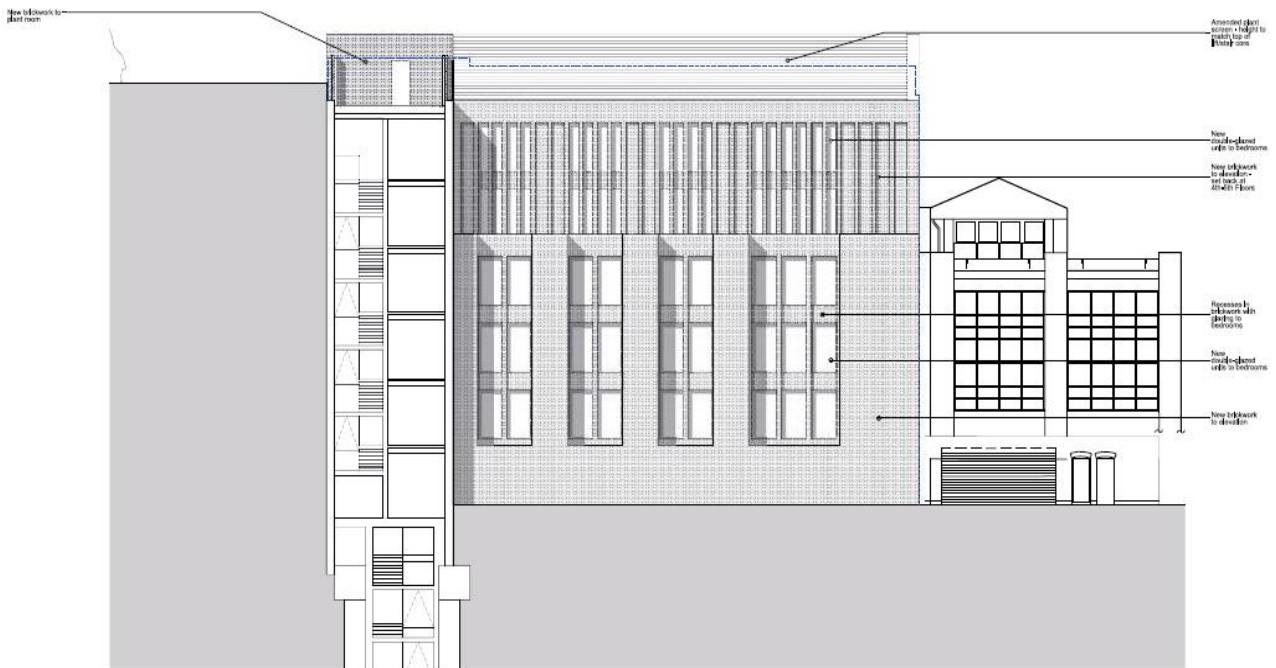

PROPOSED Rear elevation

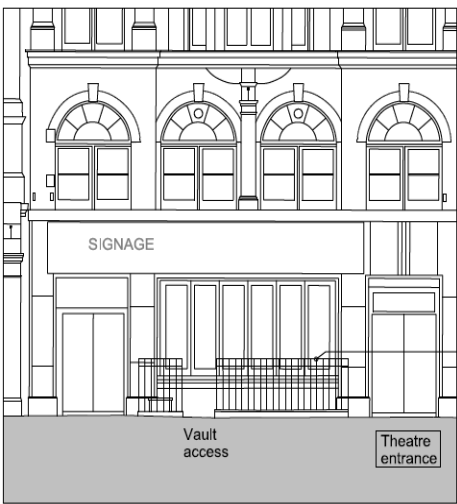
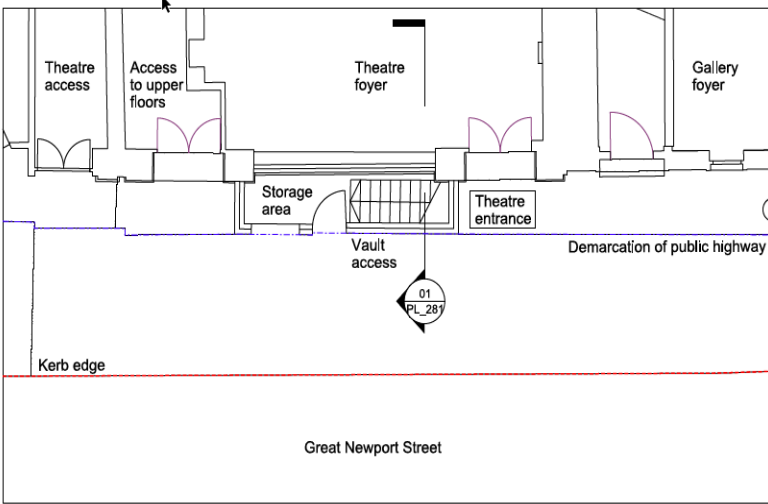

EXISTING Part plan and elevation showing front lightwell

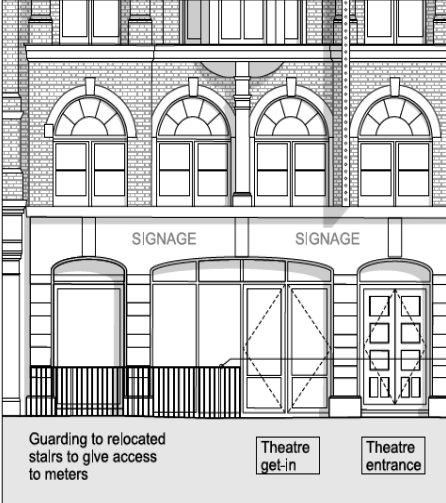
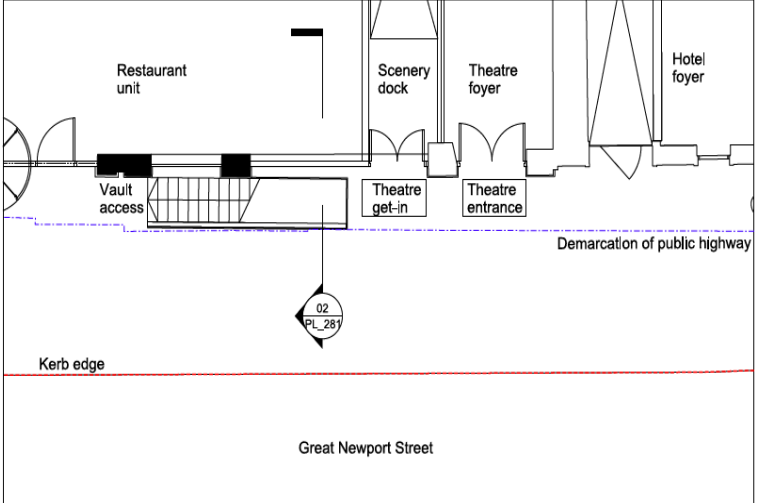

PROPOSED Part plan and elevation showing new front lightwell

DRAFT DECISION LETTER

Address: Development Site At, 5-9 Great Newport Street, London, WC2H 7JA,

Proposal: Variation of conditions 1 and 36 of planning permission dated 29 April 2016 (RN: 12/03930/FULL) for 'Demolition of Nos. 6-9 Great Newport Street behind retained front facades and demolition of rear addition to No. 5 Great Newport Street. Excavation and redevelopment to provide a building comprised of lower basement, basement, lower ground, ground and six upper floors, terraces, roof plant and alterations to front facade, providing a new auditorium and ancillary services in the form of a new flexible theatre space and arts club venue along with rehearsal studio and ancillary facilities including bars at basement level 1 and ground floor level (sui generis), restaurant (Class A3) on the ground floor and part lower ground floors and a hotel at part ground and first to sixth floor levels (across 5-9 Great Newport Street), associated hotel bar and sculpture gallery at first floor level and outdoor swimming pool, terrace and bar at fifth floor level'. Namely, to allow amendments to the consented scheme including increase the theatre capacity to over 400 seats, intensification of the hotel use from 66 rooms to 155 rooms, provide 24 cycle parking spaces, fenestration changes to rear elevation including new windows, increase the height and amount of plant within the rooftop plant enclosure, alterations to ground floor level shopfronts, creation of lightwell enclosed by railings outside 6 - 7 Great Newport Street, and internal alterations.

Reference: 18/01160/FULL

Plan Nos: RN:18/01160/FULL
1427_PL010, 1427_PL_194, 1427_PL_195, 1427_PL_196, 1427_PL_197, 1427_PL_198, 1427_PL_199, 1427_PL_200, 1427_PL_201, 1427_PL_202, 1427_PL_203, 1427_PL_204, 1427_PL_205, 1427_PL_206, 1427_PL_207, 1427_PL_260, 1427_PL_261, 1427_PL_270, 1427_PL_271, 1427_PL_272, 1427_PL_275, 1427_PL_280, 1427_PL_281
RN: 12/03930/FULL
Location Plan, 3207_00_207 B, 208 D, 209 B, 210 B, 211 C, 214 A, Existing Front Elevations (unnumbered), 3207_80, 1427_PL_28120_101 C, 102 C, 103 C, 104 C, 105 C, 106 C, 107 C, 108 C, 109 D, 110 C, 111 C, 112 C, 113 B, 200 A, 201 E, 202 E, 203 I, 204 G, 205 E, 206 F, 207 E, 208 K, 209 K, 210 H, 211 J, 212 M, 213 M, 214 H, 215 E, 216 N, 218 J, 219 D, 220 C, Design and Access Statement dated April 2012, Design and Access Statement Addendum dated November 2013, Planning Statement dated April 2012, Letter from Turley Associates dated 17.12.2013, Report of Theatre Design Consultant Ian Albery dated 09.09.2013, Letter from Ian Albery dated 16.04.2014, Report of Anne Minors dated July 2012, Letter from Anne Minors dated 09.04.2014, Historic Buildings Architect's Report dated April 2008, Heritage Statement dated April 2012, Archaeological Desktop Assessment dated April 2008, Environmental and Planning Noise Report dated 05.04.2012, Daylight and Sunlight Report dated 23.03.2012, Sustainability and Energy Report dated April 2012, Transport Assessment dated 03.04.2012. For information purposes only - Excavation and Facade Retention Feasibility Report dated April 2008, Structural Engineers Concepts Report dated 30.09.2013, Daylight and Sunlight Study dated 08 December 2014.

Case Officer: David Dorward

Direct Tel. No. 020 7641 2408

Recommended Condition(s) and Reason(s)

- 1 The development hereby permitted shall be carried out in accordance with the drawings and other documents listed on this decision letter, and any drawings approved subsequently by the City Council as local planning authority pursuant to any conditions on this decision letter.

Reason:

For the avoidance of doubt and in the interests of proper planning.

- 2 Except for basement excavation work, you must carry out any building work which can be heard at the boundary of the site only:

- * between 08.00 and 18.00 Monday to Friday;
- * between 08.00 and 13.00 on Saturday; and
- * not at all on Sundays, bank holidays and public holidays.

You must carry out basement excavation work only:

- * between 08.00 and 18.00 Monday to Friday; and
- * not at all on Saturdays, Sundays, bank holidays and public holidays.

Noisy work must not take place outside these hours. (C11BA)

Reason:

To protect the environment of neighbouring occupiers. This is as set out in S29 and S32 of Westminster's City Plan (November 2016) and ENV 6 of our Unitary Development Plan that we adopted in January 2007. (R11AC)

- 3 (1) Where noise emitted from the proposed plant and machinery will not contain tones or will not be intermittent, the 'A' weighted sound pressure level from the plant and machinery (including non-emergency auxiliary plant and generators) hereby permitted, when operating at its noisiest, shall not at any time exceed a value of 10 dB below the minimum external background noise, at a point 1 metre outside any window of any residential and other noise sensitive property, unless and until a fixed maximum noise level is approved by the City Council. The background level should be expressed in terms of the lowest LA90, 15 mins during the proposed hours of operation. The plant-specific noise level should be expressed as LAeqTm, and shall be representative of the plant operating at its maximum.
- (2) Where noise emitted from the proposed plant and machinery will contain tones or will be intermittent, the 'A' weighted sound pressure level from the plant and machinery (including non-emergency auxiliary plant and generators) hereby permitted, when operating at its noisiest, shall not at any time exceed a value of 15 dB below the minimum external background noise, at a point 1 metre outside any window of any residential and other noise sensitive property, unless and until a fixed maximum noise level is approved by the City Council. The background level should be expressed in terms of the lowest LA90, 15 mins during the proposed hours of operation. The plant-specific noise level should be expressed as LAeqTm, and shall be representative of the plant operating at its maximum.
- (3) Following installation of the plant and equipment, you may apply in writing to the City Council for a fixed maximum noise level to be approved. This is to be done by submitting a further noise report confirming previous details and subsequent measurement data of the installed plant, including a proposed fixed noise level for approval by the City Council. Your submission of a noise report must include:
- (a) A schedule of all plant and equipment that formed part of this application;
 - (b) Locations of the plant and machinery and associated: ducting; attenuation and damping equipment;
 - (c) Manufacturer specifications of sound emissions in octave or third octave detail;
 - (d) The location of most affected noise sensitive receptor location and the most affected window of it;
 - (e) Distances between plant & equipment and receptor location/s and any mitigating features that may attenuate the sound level received at the most affected receptor location;
 - (f) Measurements of existing LA90, 15 mins levels recorded one metre outside and in front of the window referred to in (d) above (or a suitable representative position), at times when background noise is at its lowest during hours when the plant and equipment will operate. This acoustic survey to be conducted in conformity to BS 7445 in respect of measurement methodology and procedures;
 - (g) The lowest existing L A90, 15 mins measurement recorded under (f) above;
 - (h) Measurement evidence and any calculations demonstrating that plant and equipment complies with the planning condition;

(i) The proposed maximum noise level to be emitted by the plant and equipment.

Reason:

Because existing external ambient noise levels exceed WHO Guideline Levels, and as set out in ENV 6 (1), (6) and (8) and ENV 7 (A)(1) of our Unitary Development Plan that we adopted in January 2007, so that the noise environment of people in noise sensitive properties is protected, including the intrusiveness of tonal and impulsive sounds; and as set out in S32 of Westminster's City Plan (November 2016), by contributing to reducing excessive ambient noise levels. Part (3) is included so that applicants may ask subsequently for a fixed maximum noise level to be approved in case ambient noise levels reduce at any time after implementation of the planning permission.

- 4 No vibration shall be transmitted to adjoining or other premises and structures through the building structure and fabric of this development as to cause a vibration dose value of greater than 0.4m/s (1.75) 16 hour day-time nor 0.26 m/s (1.75) 8 hour night-time as defined by BS 6472 (2008) in any part of a residential and other noise sensitive property.

Reason:

As set out in ENV6 (2) and (6) of our Unitary Development Plan that we adopted in January 2007, to ensure that the development is designed to prevent structural transmission of noise or vibration.

- 5 You must apply to us for approval of details of a supplementary acoustic report demonstrating that the plant will comply with the Council's noise criteria as set out in Condition 3 of this permission. You must not start work on this part of the development until we have approved what you have sent us.

Reason:

Because existing external ambient noise levels exceed WHO Guideline Levels, and as set out in ENV 6 (1), (6) and (8) and ENV 7 (A)(1) of our Unitary Development Plan that we adopted in January 2007, so that the noise environment of people in noise sensitive properties is protected, including the intrusiveness of tonal and impulsive sounds; and as set out in S32 of Westminster's City Plan (November 2016), by contributing to reducing excessive ambient noise levels.

- 6 Before anyone moves into the property, you must provide the separate stores for waste and materials for recycling shown on drawing number 1427_PL_199 and 1427_PL_200. You must clearly mark them and make them available at all times to everyone using the uses hereby approved. (C14FB)

Reason:

To protect the environment and provide suitable storage for waste as set out in S44 of Westminster's City Plan (November 2016) and ENV 12 of our Unitary Development Plan that we adopted in January 2007. (R14BD)

- 7 Notwithstanding what is shown on the plans, you must hang all doors or gates so that they do not open over or across the road or pavement.

Reason:

In the interests of public safety and to avoid blocking the road as set out in S41 of Westminster's City Plan (November 2016) and TRANS 2 and TRANS 3 of our Unitary Development Plan that we adopted in January 2007. (R24AC)

- 8 The development hereby permitted shall not be commenced until detailed design and method statements (in consultation with London Underground) for all of the foundations, basement and ground floor structures, or for any other structures below ground level, including piling (temporary and permanent), have been submitted to and approved in writing by the local planning authority which:
- provide details on all structures;
 - accommodate the location of the existing London Underground structures and tunnels;
 - accommodate ground movement arising from the construction thereof; and
 - mitigate the effects of noise and vibration arising from the adjoining operations within the structures and tunnels.

The development shall thereafter be carried out in all respects in accordance with the approved design and method statements, and all structures and works comprised within the development hereby permitted which are required by the approved design statements in order to procure the matters mentioned in paragraphs of this condition shall be completed, in their entirety, before any part of the building hereby permitted is occupied.

Reason:

To ensure that the development does not impact on existing London Underground transport infrastructure, in accordance with London Plan policy 3C.4 and 'Land for Transport Functions' Supplementary Planning Guidance.

- 9 **Pre Commencement Condition.** You must apply to us for approval of a detailed design and method statement relating to the foundations and all new ground work. You must not start any construction work until we have approved what you have sent us., You must then carry out the work according to the approved design and method statement. (C32AB)

Reason:

To avoid damage to any archaeological remains on site as set out in S25 of Westminster's City Plan (November 2016) and DES 11 of our Unitary Development Plan that we adopted in January 2007. (R32AC)

- 10 **Pre Commencement Condition.**

(a) You must apply to us for approval of a written scheme of investigation for a programme of archaeological work. This must include details of the suitably qualified person or organisation that will carry out the archaeological work. You must not start work until we have approved what you have sent us.

(b) You must then carry out the archaeological work and development according to this approved scheme. You must produce a written report of the investigation and findings, showing that you have carried out the archaeological work and development according to the approved scheme. You must send copies of the written report of the investigation and findings to us, to Historic England, and to the Greater London Sites and Monuments Record, 1 Waterhouse Square, 138-142 Holborn, London EC1N 2ST., , (c) You must not use any part of the new building until we have confirmed that you have carried out the archaeological fieldwork and development according to this approved scheme. (C32BC)

Reason:

To protect the archaeological heritage of the City of Westminster as set out in S25 of Westminster's City Plan (November 2016) and DES 11 of our Unitary Development Plan that we adopted in January 2007. (R32BC)

- 11 No works of demolition authorised by this permission shall take place until the applicant has implemented a programme of building recording and analysis of the existing Arts Theatre by person or body approved by the Council as local planning authority. This programme shall be in accordance with a written scheme which has been submitted by the applicant and approved by the local planning authority advised by the

Theatres Trust. The recording shall then be carried out according to the written scheme and no demolition work shall be carried out until the recording and analysis report has been received and approved by the City Council advised by the Theatres Trust.

Reason:

To ensure that the history of the site is recorded as set out in DES 11 of the 2007 UDP.

- 12 You must apply to us for approval of an operational management plan in relation to the hotel, restaurant and theatre. This should include details to show how you will control the use of the rooftop pool and terrace and how you will prevent customers who are leaving the buildings from causing nuisance for people in the area, including people who live in nearby buildings. You must not start the hotel, restaurant and/or theatre use until we have approved what you have sent us. You must then carry out the measures included in the management plan at all times that the hotel, restaurant and/or theatre is in use.

Reason:

To make sure that the use will not cause nuisance for people in the area. This is as set out in S24, S29 and S32 of Westminster's City Plan (November 2016) and TACE 6 and 8 and ENV 6 of our Unitary Development Plan that we adopted in January 2007. (R05GB)

- 13 No development shall take place, including any works of demolition, until a construction management plan for the proposed development has been submitted to and approved in writing by the City Council as local planning authority. The plan must include the following details (where appropriate):
- (i) a construction programme including a 24 hour emergency contact number;
 - (ii) parking of vehicles of site operatives and visitors (including measures taken to ensure satisfactory access and movement for existing occupiers of neighbouring properties during construction);,
 - (iii) locations for loading/unloading and storage of plant and materials used in constructing the development;,
 - (iv) erection and maintenance of security hoardings (including decorative displays and facilities for public viewing, where appropriate);,
 - (v) wheel washing facilities and measures to control the emission of dust and dirt during construction; and,
 - (vi) a scheme for recycling/disposing of waste resulting from demolition and construction works.
- You must not start work until we have approved what you have sent us. You must then carry out the development in accordance with the approved details. (C21MB)

Reason:

To protect the environment of residents and the area generally as set out in S29 of Westminster's City Plan: Strategic Policies adopted November 2013 and TRANS 23, ENV 5 and ENV 6 of our Unitary Development Plan that we adopted in January 2007.

- 14 The restaurant area shall be restricted to the area shown on the approved drawings and shall contain no more than 100 covers.

Reason:

We cannot grant planning permission for unrestricted use in this case because it would not meet TACE 8 of our Unitary Development Plan that we adopted in January 2007. (R05AB)

- 15 No customer, hotel resident or guest shall be permitted onto the rooftop terrace and pool area before 0800 or after 2200 each day.

Reason:

To protect the environment of people in neighbouring properties as set out in S24, S29 and S32 of Westminster's City Plan (November 2016) and ENV 6, ENV 7 and TACE 2 of our Unitary Development Plan that we adopted in January 2007. (R12AC)

- 16 All new work to the outside of the building must match existing original work in terms of the choice of materials, method of construction and finished appearance. This applies unless differences are shown on the drawings we have approved or are required by conditions to this permission. (C26AA)

Reason:

To make sure that the appearance of the building is suitable and that it contributes to the character and appearance of this part of the Covent Garden Conservation Area. This is as set out in S25 and S28 of Westminster's City Plan (November 2016) and DES 1 and DES 5 or DES 6 or both and paras 10.108 to 10.128 of our Unitary Development Plan that we adopted in January 2007. (R26BE)

- 17 You must apply to us for approval of details of the following parts of the development with detailed drawings at a scale of 1:10 and full size details –

- (i) all new windows and external doors,
- (ii) new canopy over theatre entrance,
- (iii) plant screen at roof level,
- (iv) all new shopfronts,

You must not start any work on these parts of the development until we have approved what you have sent us. You must then carry out the work according to these approved drawings.

Reason:

To make sure that the appearance of the building is suitable and that it contributes to the character and appearance of this part of the Covent Garden Conservation Area. This is as set out in S25 and S28 of Westminster's City Plan (November 2016) and DES 1 and DES 5 or DES 6 or both and paras 10.108 to 10.128 of our Unitary Development Plan that we adopted in January 2007. (R26BE)

- 18 You must apply to us for approval of a sample panel of brickwork which shows the colour, texture, face bond and pointing. You must not start work on this part of the development until we have approved what you have sent us. You must then carry out the work according to the approved sample. (C27DB)

Reason:

To make sure that the appearance of the building is suitable and that it contributes to the character and appearance of this part of the Covent Garden Conservation Area. This is as set out in S25 and S28 of Westminster's City Plan (November 2016) and DES 1 and DES 5 or DES 6 or both and paras 10.108 to 10.128 of our Unitary Development Plan that we adopted in January 2007. (R26BE)

- 19 You must not put any machinery or associated equipment, ducts, tanks, satellite or radio aerials on the roof, except those shown on the approved drawings. (C26PA)

Reason:

To make sure that the appearance of the building is suitable and that it contributes to the character and appearance of this part of the Covent Garden Conservation Area. This is as set out in S25 and S28 of Westminster's City Plan (November 2016) and DES 1 and DES 5 or DES 6 or both and paras 10.108 to 10.128 of our Unitary Development Plan that we adopted in January 2007. (R26BE)

- 20 You must apply to us for approval of samples of the facing materials you will use, including glazing, and elevations and roof plans annotated to show where the materials are to be located. You must not start any work on these parts of the development until we have approved what you have sent us. You must then carry out the work using the approved materials. (C26BC)

Reason:

To make sure that the appearance of the building is suitable and that it contributes to the character and appearance of this part of the Covent Garden Conservation Area. This is as set out in S25 and S28 of Westminster's City Plan (November 2016) and DES 1 and DES 5 or DES 6 or both and paras 10.108 to 10.128 of our Unitary Development Plan that we adopted in January 2007. (R26BE)

- 21 The design and structure of the development shall be of such a standard that it will protect residents within the same building or in adjoining buildings from noise and vibration from the development, so that they are not exposed to noise levels indoors of more than 35 dB LAeq 16 hrs daytime and of more than 30 dB LAeq 8 hrs in bedrooms at night.

Reason:

As set out in ENV6 of our Unitary Development Plan that we adopted in January 2007, and the related Policy Application at section 9.76, in order to ensure that design, structure and acoustic insulation of the development will provide sufficient protection for residents of the same or adjoining buildings from noise and vibration from elsewhere in the development.

- 22 You must put a copy of this planning permission and all its conditions at street level outside the building for as long as the work continues on site., , You must highlight on the copy of the planning permission any condition that restricts the hours of building work. (C21KA)

Reason:

To make sure people in neighbouring properties are fully aware of the conditions and to protect their rights and safety. (R21GA)

- 23 You must apply to us for approval of detailed drawings showing the following alteration(s) to the scheme - All new rooftop balustrades to be made of black painted metal. You must not start on these parts of the work until we have approved what you have sent us. You must then carry out the work according to the approved drawings. (C26UB)

Reason:

To make sure that the appearance of the building is suitable and that it contributes to the character and appearance of this part of the Covent Garden Conservation Area. This is as set out in S25 and S28 of Westminster's City Plan (November 2016) and DES 1 and DES 5 or DES 6 or both and paras 10.108 to 10.128 of our Unitary Development Plan that we adopted in January 2007. (R26BE)

- 24 **Pre Commencement Condition.** You must apply to us for approval of detailed drawings showing how you will support and protect the parts of the building which are to be kept during building work. You must not start work until we have approved what you have sent us. You must then carry out the work according to these drawings. (C28AB)

Reason:

To protect the parts of the building which are to be preserved during building work. (R28AA)

- 25 You must apply to us for approval of a Servicing Management Plan, which includes details of how the hotel, restaurant and theatre will be serviced, including details proposing the hours of servicing for each use. You must not occupy the hotel or restaurant until we have approved what you have sent us. Thereafter you must then manage the servicing in accordance with the Servicing Management Plan that we approve, unless we agree an alternative Servicing Management Plan in writing.

Reason:

To avoid blocking the surrounding streets and to protect the environment of people in neighbouring properties as set out in S42 of Westminster's City Plan (November 2016) and STRA 25, TRANS 20 and TRANS 21 of our Unitary Development Plan that we adopted in January 2007. (R23AC)

- 26 The development shall achieve an 'Very Good' rating under the BREEAM 2011 New Construction Assessment Scheme (or any such national measure of sustainability for design that replaces that scheme of the same standard).

Reason:

To make sure that the development affects the environment as little as possible, as set out in S28 or S40, or both, of Westminster's City Plan (November 2016). (R44BC)

- 27 The BREEAM assessment required by condition 26 must be completed and certified by the Building Research Establishment and a copy of the certificate detailing the award score for the building shall be submitted to us within 3 months of first occupation. In the event that this fails to meet the proposed 'Very Good' rating (or equivalent) a full schedule of costs and works to achieve such a rating shall be submitted at the same time. In the event that the Council considers it is practicable and reasonable to require the implementation of these remedial works to achieve such a rating such measures, or alternatives to secure off site remedial actions, shall be carried out within six months of any such determination.

Reason:

To make sure that the development affects the environment as little as possible, as set out in S28 or S40, or both, of Westminster's City Plan (November 2016). (R44BC)

- 28 You must not allow more than 120 customers into the hotel bar at first floor level at any one time. The first floor bar area is the part of the property annotated on approved drawing no. 3207_20_204 F as the 'Sculpture Gallery/Hotel Terrace'.

Reason:

To make sure that the use will not cause nuisance for people in the area. This is as set out in S24, S29 and S32 of Westminster's City Plan (November 2016) and TACE 2 and ENV 6 of our Unitary Development Plan that we adopted in January 2007. (R05GB)

- 29 You must not allow a total of more than 100 customers into the hotel bar and terrace at fifth floor level at any one time. The fifth floor bar area and external terrace is the part of the property shown on approved drawing no. 3207_20_208 H.

Reason:

To make sure that the use will not cause nuisance for people in the area. This is as set out in S24, S29 and S32 of Westminster's City Plan (November 2016) and TACE 2 and ENV 6 of our Unitary Development Plan that we adopted in January 2007. (R05GB)

- 30 Customers shall not be permitted within the restaurant premises before 0800hrs or after 0000hrs (midnight) Sunday to Wednesday, or before 0800hrs and 0100hrs Fridays to Saturdays.

Reason:

To make sure that the use will not cause nuisance for people in the area. This is as set out in S24, S29 and S32 of Westminster's City Plan (November 2016) and TACE 10 and ENV 6 of our Unitary Development Plan that we adopted in January 2007. (R05GB)

- 31 The first and fifth floor bar areas within the hotel hereby approved shall not be open to customers (other than hotel residents (those staying overnight at the hotel)) between the following times: 0900hrs to 0000hrs (midnight) Monday to Thursday; and 0900hrs to 0030hrs Friday to Sunday.

Reason:

To make sure that the use will not cause nuisance for people in the area. This is as set out in S24, S29 and S32 of Westminster's City Plan (November 2016) and TACE TACE 2 and ENV 6 of our Unitary Development Plan that we adopted in January 2007. (R05GB)

- 32 Customers shall not be permitted within the theatre premises before 0800hrs or after 0000hrs (midnight) Sunday to Wednesday, or before 0800hrs and 0200hrs Fridays to Saturdays.

Reason:

To make sure that the use will not cause nuisance for people in the area. This is as set out in S24, S29 and S32 of Westminster's City Plan (November 2016) and TACE 6 and ENV 6 of our Unitary Development Plan that we adopted in January 2007. (R05GB)

- 33 You must provide the access and all additional facilities including accessible toilets and theatre seating for people with disabilities as shown on the approved drawings before you use the building.

Reason:

To make sure that there is reasonable access for people with disabilities and to make sure that the access does not harm the appearance of the building, as set out in S28 of Westminster's City Plan: Strategic Policies adopted November 2013 and DES 1 (B) of our Unitary Development Plan that we adopted in January 2007.

- 34 You must apply to us for approval of detailed drawings of the following parts of the development-
- detailed plans showing the route of the kitchen extract ducts through the building and detailed plans, section and elevation of where where they terminate to the external parts of the building.
- detailed plans and sections of the glazed roof to the hotel atrium.
You must not start work on the development above ground level until we have approved what you have sent us. You must then carry out the work according to these approved drawings.

Reason:

To make sure that the appearance of the building is suitable and that it contributes to the character and

appearance of this part of the Conservation Area. This is as set out in S25 and S28 of Westminster's City Plan (November 2016) and DES 1 and DES 5 or DES 6 or both and paras 10.108 to 10.128 of our Unitary Development Plan that we adopted in January 2007. (R26BE)

- 35 You must not create any additional useable floorspace within the hotel atrium.

Reason:

To make sure that the development provides the planning benefits that have been agreed, as set out in S33 of Westminster's City Plan (November 2016) and in SOC 1 of our Unitary Development Plan that we adopted in January 2007. (R19AC)

- 36 The theatre must provide 400 seats or more.

Reason:

Because of the special circumstances of this case and to make sure it meets S22 of Westminster's City Plan: Strategic Policies adopted November 2013 and TACE 5 and TACE 6 of our Unitary Development Plan that we adopted in January 2007.

- 37 The flat roof areas at the rear of the new building as a result of the setbacks should not be used as terraces or for sitting out or for any other purpose. You can however use the flat roof areas to escape in an emergency (C21AA).

Reason:

To protect the privacy and environment of people in neighbouring properties. This is as set out in S29 and S32 of Westminster's City Plan (November 2016) and ENV 6 and ENV 13 of our Unitary Development Plan that we adopted in January 2007. (R21BC)

- 38 You must not use the roof of the building for sitting out or for any other purpose. You can however use the roof to escape in an emergency. (C21AA)

Reason:

To protect the privacy and environment of people in neighbouring properties. This is as set out in S29 and S32 of Westminster's City Plan (November 2016) and ENV 6 and ENV 13 of our Unitary Development Plan that we adopted in January 2007. (R21BC)

- 39 No waste should be left or stored on the public highway.

Reason:

In the interests of public safety and to avoid blocking the road as set out in S41 of Westminster's City Plan (November 2016) and TRANS 2 and TRANS 3 of our Unitary Development Plan that we adopted in January 2007. (R24AC)

- 40 The hotel shall not knowingly accept bookings from parties using a vehicle with a capacity of 14 or more persons to travel to and from the premises.

Reason:

To avoid blocking the surrounding streets and to protect the environment of people in neighbouring properties as set out in S42 of Westminster's City Plan (November 2016) and STRA 25, TRANS 20 and TRANS 21 of our Unitary Development Plan that we adopted in January 2007.

- 41 This permission must be commenced no later than 29 April 2019.

Reason:

This permission authorises amendments to the original planning permission granted on 29 April 2016 (RN 12/03930/FULL) which must be commenced no later than the above date.

Informative(s):

- 1 In dealing with this application the City Council has implemented the requirement in the National Planning Policy Framework to work with the applicant in a positive and proactive way. We have made available detailed advice in the form of our statutory policies in Westminster's City Plan (November 2016), Unitary Development Plan, Supplementary Planning documents, planning briefs and other informal written guidance, as well as offering a full pre application advice service, in order to ensure that applicant has been given every opportunity to submit an application which is likely to be considered favourably. In addition, where appropriate, further guidance was offered to the applicant at the validation stage.
- 2 The applicant is advised to contact London Underground Infrastructure Protection in advance of preparation of final design and associated method statements, in particular with regard to; demolition; excavation; construction methods; security; boundary treatment; safety barriers; landscaping and lighting.
- 3 Please contact our District Surveyors' Services to discuss how you can design for the inclusion of disabled people. Email: districtsurveyors@westminster.gov.uk. Phone 020 7641 7240 or 020 7641 7230. If you make a further planning application or a building regulations application which relates solely to providing access or facilities for people with disabilities, our normal planning and building control fees do not apply., , The Equality and Human Rights Commission has a range of publications to assist you, see www.equalityhumanrights.com. The Centre for Accessible Environment's 'Designing for Accessibility', 2004, price £22.50 is a useful guide, visit www.cae.org.uk. , , If you are building new homes you must provide features which make them suitable for people with disabilities. For advice see www.habinteg.org.uk , , It is your responsibility under the law to provide good access to your buildings. An appropriate and complete Access Statement as one of the documents on hand-over, will provide you and the end user with the basis of a defence should an access issue be raised under the Disability Discrimination Acts.
- 4 Please make sure that the street number and building name (if applicable) are clearly displayed on the building. This is a condition of the London Building Acts (Amendments) Act 1939, and there are regulations that specify the exact requirements. (I54AA)
- 5 The development will result in changes to road access points. Any new threshold levels in the building must be suitable for the levels of neighbouring roads. If you do not plan to make changes to the road and pavement you need to send us a drawing to show the threshold and

existing road levels at each access point., , If you need to change the level of the road, you must apply to our Highways section at least eight weeks before you start work. You will need to provide survey drawings showing the existing and new levels of the road between the carriageway and the development. You will have to pay all administration, design, supervision and other costs. We will carry out any work which affects the road. For more advice, please phone 020 7641 2642. (I69AA)

- 6 Please contact our Cleansing section on 020 7641 7962 about your arrangements for storing and collecting waste. (I08AA)
- 7 We recommend you speak to the Head of the District Surveyors' Services about the stability and condition of the walls to be preserved. He may ask you to carry out other works to secure the walls. Please phone 020 7641 7240 or 020 7641 7230. (I22AA)
- 8 You must apply for a licence from our Highways Licensing Team if you plan to block the road or pavement during structural work to support the building. Your application will need to show why you cannot support the building from private land. For more advice, please phone 020 7641 2560. (I36AA)
- 9 You are encouraged to join the nationally recognised Considerate Constructors Scheme. This commits those sites registered with the Scheme to be considerate and good neighbours, as well as clean, respectful, safe, environmentally conscious, responsible and accountable. For more information please contact the Considerate Constructors Scheme directly on 0800 783 1423, siteenquiries@ccscheme.org.uk or visit www.ccscheme.org.uk.
- 10 The development for which planning permission has been granted has been identified as potentially liable for payment of both the Mayor of London and Westminster City Council's Community Infrastructure Levy (CIL). Further details on both Community Infrastructure Levies, including reliefs that may be available, can be found on the council's website at: , www.westminster.gov.uk/cil , Responsibility to pay the levy runs with the ownership of the land, unless another party has assumed liability. If you have not already you must submit an **Assumption of Liability Form immediately**. On receipt of this notice a CIL Liability Notice setting out the estimated CIL charges will be issued by the council as soon as practicable, to the landowner or the party that has assumed liability, with a copy to the planning applicant. You must also notify the Council before commencing development using a **Commencement Form** , CIL forms are available from the planning on the planning portal: , <http://www.planningportal.gov.uk/planning/applications/howtoapply/whattosubmit/cil> , Forms can be submitted to CIL@Westminster.gov.uk , **Payment of the CIL charge is mandatory and there are strong enforcement powers and penalties for failure to pay, including Stop Notices, surcharges, late payment interest and prison terms.**
- 11 Developing this site is likely to damage archaeological remains. Archaeological work must be carried out in line with condition . Please contact English Heritage's Archaeological Officer on 020 7973 3732 to discuss the work which is necessary. (I66AA)
- 12 You are advised that all illuminated advertisements or high level advertisements require express advertisement consent before they can be displayed. Notwithstanding what is shown on the approved drawings this permission does not approve the display of such advertisements.

Item No.
3

Please note: the full text for informatives can be found in the Council's Conditions, Reasons & Policies handbook, copies of which can be found in the Committee Room whilst the meeting is in progress, and on the Council's website.

DRAFT DECISION LETTER

- Address:** Development Site At, 5-9 Great Newport Street, London, WC2H 7JA
- Proposal:** Variation of condition 1 of listed building consent dated 29 April 2016 (RN: 12/03931/LBC) for 'Demolition of rear addition to No. 5 Great Newport Street, and internal alterations within listed building at No. 5. Works in association with works at Nos. 6-9 Great Newport Street to carry out partial demolition behind retained front facades, excavation and redevelopment to provide a building comprised of basement, lower ground, ground and six upper floors, terraces, roof plant and alterations to facade, for a new theatre and ancillary facilities at ground floor (part) basement and lower ground floor levels, restaurant (Class A3) on the ground floor and lower ground floors and a hotel at ground floor (part) and first to sixth floor levels, associated hotel bar and sculpture gallery at part ground floor level'. Namely, to allow amendments to the consented scheme including increase the theatre capacity to over 400 seats, intensification of the hotel use from 66 rooms to 155 rooms, provide 24 cycle parking spaces, fenestration changes to rear elevation including new windows, increase the height and amount of plant within the rooftop plant enclosure, alterations to ground floor level shopfronts, creation of lightwell enclosed by railings outside 6 - 7 Great Newport Street, and internal alterations linked to 18/01160/FULL.
- Plan Nos:** RN: 18/05525/LBC
 1427_PL010, 1427_PL_194, 1427_PL_195, 1427_PL_196, 1427_PL_197,
 1427_PL_198, 1427_PL_199, 1427_PL_200, 1427_PL_201, 1427_PL_202,
 1427_PL_203, 1427_PL_204, 1427_PL_205, 1427_PL_206, 1427_PL_207,
 1427_PL_260, 1427_PL_261, 1427_PL_270, 1427_PL_271, 1427_PL_272,
 1427_PL_275, 1427_PL_280, 1427_PL_281
 RN: 12/03931/LBC
 Location Plan, 3207_00_207 B, 208 D, 209 B, 210 B, 211 C, 214 A, Existing Front Elevations (unnumbered), 3207_20_101 C, 102 C, 103 C, 104 C, 105 C, 106 C, 107 C, 108 C, 109 D, 110 C, 111 C, 112 C, 113 B, 200 A, 201 E, 202 E, 203 I, 204 G, 205 E, 206 F, 207 E, 208 K, 209 K, 210 H, 211 J, 212 M, 213 M, 214 H, 215 E, 216 N, 218 J, 219 D, 220 C, Design and Access Statement dated April 2012, Design and Access Statement Addendum dated November 2013, Historic Buildings Architect's Report dated April 2008, Heritage Statement dated April 2012, Archaeological Desktop Assessment dated April 2008.

Case Officer: David Dorward **Direct Tel. No.** 020 7641 2408

Recommended Condition(s) and Reason(s) or Reason(s) for Refusal:

- 1 The development hereby permitted shall be carried out in accordance with the drawings and other documents listed on this decision letter, and any drawings approved subsequently by the City Council as local planning authority pursuant to any conditions on this decision letter.

Reason:

For the avoidance of doubt and in the interests of proper planning.

- 2 All new work and improvements inside and outside the building must match existing original adjacent work in terms of the choice of materials, method of construction and finished appearance. This applies unless differences are shown on the approved drawings or are required in conditions to this permission. (C27AA)

Reason:

To protect the special architectural or historic interest of this building and to make sure the development contributes to the character and appearance of the Covent Garden Conservation Area. This is as set out in S25 and S28 of Westminster's City Plan (November 2016) and DES 1 and paras 10.108 to 10.146 of our Unitary Development Plan that we adopted in January 2007. (R27AC)

- 3 You must apply to us for approval of details of the following parts of the development with detailed drawings at a scale of 1:10 and full size details -

- (i) all new secondary glazing
- (ii) all new doors

You must not start any work on these parts of the development until we have approved what you have sent us.

You must then carry out the work according to these approved details. (C26DB)

Reason:

To protect the special architectural or historic interest of this listed building. This is as set out in S25 and S28 of Westminster's City Plan (November 2016) and DES 1 of our Unitary Development Plan that we adopted in January 2007, and paragraph 2.3 and 2.4 of our Supplementary Planning Guidance: Repairs and Alterations to Listed Buildings. (R27BC)

- 4 All existing floorboards are to be retained in situ.

Reason:

To protect the special architectural or historic interest of this listed building. This is as set out in S25 and S28 of Westminster's City Plan (November 2016) and DES 1 of our Unitary Development Plan that we adopted in January 2007, and paragraph 2.3 and 2.4 of our Supplementary Planning Guidance: Repairs and Alterations to Listed Buildings. (R27BC)

- 5 You must apply to us for approval of the following parts of the development:

- 1) A historic paint analysis report and colour samples and drawings annotated to show new decorative schemes for all rooms and the main staircase,
- 2) Details of the scope of paint removal and plasterwork repairs,
- 3) Details of the installation of mechanical and electrical services where they affect historic fabric,
- 4) A method statement and schedule setting out all works of repair and restoration to carpentry, joinery, and plasterwork.

You must not start any work on these parts of the development until we have approved what you have sent us.

You must then carry out the work according to these details.

Reason:

To protect the special architectural or historic interest of this listed building. This is as set out in S25 and S28 of Westminster's City Plan (November 2016) and DES 1 of our Unitary Development Plan that we adopted in January 2007, and paragraph 2.3 and 2.4 of our Supplementary Planning Guidance: Repairs and Alterations to Listed Buildings. (R27BC)

- 6 **Pre Commencement Condition.** You must apply to us for approval of detailed drawings of the following parts of the development-

- detailed plans showing the route of the kitchen extract ducts through the building and detailed plans, section and elevation of where where they terminate to the external parts of the building
- detailed plans and sections of the glazed roof to the hotel atrium

You must not start work until we have approved what you have sent us.

You must then carry out the work according to these approved drawings.

Reason:

To protect the special architectural or historic interest of this listed building. This is as set out in S25 and S28 of Westminster's City Plan (November 2016) and DES 1 of our Unitary Development Plan that we adopted in January 2007, and paragraph 2.3 and 2.4 of our Supplementary Planning Guidance: Repairs and Alterations to Listed Buildings. (R27BC)

Informative(s):

- 1 **SUMMARY OF REASONS FOR GRANTING CONDITIONAL LISTED BUILDING CONSENT -**
In reaching the decision to grant listed building consent with conditions, the City Council has had regard to the relevant policies in the National Planning Policy Framework March 2012, the London Plan March 2016, Westminster's City Plan (November 2016), and the City of Westminster Unitary Development Plan adopted January 2007, as well as relevant supplementary planning guidance, representations received and all other material considerations.

The City Council decided that the proposed works would not harm the special architectural and historic interest of this listed building.

In reaching this decision the following were of particular relevance:

S25 and S28 of Westminster's City Plan and DES 10 including paras 10.130 to 10.146 of the Unitary Development Plan, and paragraph 2.3 and 2.4 of our Supplementary Planning Guidance: Repairs and Alterations to Listed Buildings.

2 You will need to contact us again if you want to carry out work on the listed building which is not referred to in your plans. This includes:

- * any extra work which is necessary after further assessments of the building's condition;
- * stripping out or structural investigations; and
- * any work needed to meet the building regulations or other forms of statutory control.

Please quote any 'TP' and 'RN' reference numbers shown on this consent when you send us further documents.

It is a criminal offence to carry out work on a listed building without our consent. Please remind your client, consultants, contractors and subcontractors of the terms and conditions of this consent. (159AA)

Item No.

~~5~~

CITY OF WESTMINSTER			
PLANNING APPLICATIONS COMMITTEE	Date 12 April 2016	Classification For General Release	
Addendum Report of Director of Planning		Ward(s) involved St James's	
Subject of Report	5-9 Great Newport Street, London, WC2H 7JB		
Proposal	Demolition of Nos. 6-9 Great Newport Street behind retained front facades and demolition of rear addition to No. 5 Great Newport Street. Excavation and redevelopment to provide a building comprised of lower basement, basement, lower ground, ground and six upper floors, terraces, roof plant and alterations to front facade, providing a new auditorium and ancillary services in the form of a new flexible 322 seat theatre space and arts club venue along with rehearsal studio and ancillary facilities including bars at basement level 1 and ground floor level (sui generis), restaurant (Class A3) on the ground floor and part lower ground floors and a 66 bedroom hotel at part ground and first to sixth floor levels (across 5-9 Great Newport Street), associated hotel bar and sculpture gallery at first floor level and outdoor swimming pool, terrace and bar at fifth floor level.		
Agent	Iceni Projects		
On behalf of	Consolidated Development Ltd		
Registered Number	12/03930/FULL and 12/03931/LBC	Date amended/ completed	
Date Application Received	19 April 2012		
Historic Building Grade	Grade II		
Conservation Area	Covent Garden		

1. RECOMMENDATION

Does Committee agree that:

1. Securing 'PW (Peter Wilson) Productions Ltd' as a theatre operator, would offer sufficient reassurance that a theatre will be provided, and balances the loss of the existing D1 floorspace and increase in commercial floorspace without any residential uplift.
2. The offer to provide the theatre at a rent level agreed between the applicant and 'PW (Peter Wilson) Productions Ltd' is sufficient to justify overturning the City Council's normal policy requirements to protect the existing D1 floorspace, and to provide residential floorspace or a financial contribution to the affordable housing fund in lieu of residential floorspace to address the uplift in commercial

floorspace.

3. The amendments to the rear elevation (reduction in height and bulk at fourth and fifth floor levels) together with the submission of an addendum Sunlight/ Daylight Report, addresses concerns regarding the impact upon residents in Sandringham Flats.
4. The operating hours of the restaurant and bar detailed in the report and the amended hours of use of the roof top terrace and pool area to 0900 - 2200 hours (as requested by committee) are acceptable despite requests by the applicant to revisit these hours and extend the hours of the restaurant and bar.
5. The applicant's draft legal agreement dated 02 March 2016 is sufficiently robust to secure provision of the replacement theatre fitted-out to shell and core prior to occupation of the hotel and restaurant, in addition to the provision and retention of a publicly accessible curated sculpture gallery within the hotel to compensate for the loss of the photographer's gallery, and to ensure that the £600,000 being offered is only used to fit out the theatre.
6. Subject to 1 - 5 above, resolve to grant conditional permission subject to the completion of a section 106 legal agreement to secure the following :
 - a) The provision of a replacement theatre fitted out to shell and core prior to the occupation of the hotel and restaurant.
 - b) The placing of £600,000 (index linked to when this was previously agreed by committee in 2014) into an escrow account to be released to a theatre operator to fund the fit out of the theatre.
 - c) To secure the Theatre space to be operated by 'PW (Peter Wilson) Productions Ltd' or another theatre operator with West End experience proposed by the Developer and approved by the Council or a theatre operator determined by a senior representative from the Theatres Trust to have West End experience.
 - d) The theatre space to be used for theatrical performances on at least 320 days a year (further details within the legal agreement).
 - e) To ensure the link between the theatre and restaurant is open before, during and after performances.
 - f) The provision and retention of a publicly accessible curated sculpture gallery within the hotel.
 - g) The applicant to comply with the Council's Code of Construction Practice, provide a Site Environmental Management Plan prior to commencement of development and provide a financial contribution of £(TBC by Council's Environmental Sciences Team) per annum during demolition and construction to fund the Environmental Inspectorate and monitoring by Environmental Sciences officers.
 - h) s106 monitoring costs.
7. If the agreement has not been completed by 31 July 2016 then:

a) The Director of Planning shall consider whether it would be possible and appropriate to issue the permission with additional conditions attached to secure the benefits listed above. If so, the Strategic Director is authorised to determine and issue the decision under Delegated Powers; however, if not

b) The Director of Planning shall consider whether the permission should be refused on the grounds that it has not proved possible to complete an agreement within an appropriate timescale, and that the proposals are unacceptable in the absence of the benefits which would have been secured; if so, the Strategic Director is authorised to determine the application and agree appropriate reasons for refusal under Delegated Powers.

8. Grant conditional listed building consent.

9. Agree the reasons for granting listed building consent as set out in informative 1 of the draft decision letter.

2. SUMMARY

The application was considered by Planning Committee on 13 May 2014 where it was deferred to allow the applicants to address the following issues raised by the committee:

1. The committee welcomed the reinstatement of the theatre in principle but noted that failure to secure an acceptable operator was a key issue. Members therefore agreed that, if the City Council were to accept the loss of the existing D1 floorspace and increase in commercial floorspace without any residential uplift, then confirmation of an acceptable operator would be necessary to offer sufficient reassurance that a theatre will be provided.
2. The committee further agreed that the applicant will need to offer the new theatre at peppercorn rent in order to justify overturning the City Council's normal policy requirements to protect the existing D1 floorspace, and to provide residential floorspace or a financial contribution to the affordable housing fund in lieu of residential floorspace to address the uplift in commercial floorspace.
3. Members raised concerns regarding the significant proposed increase in the height and bulk of the rear of the building and the detrimental impact upon residents in Sandringham Flats. The committee therefore requested that the height and bulk of the proposed extension be addressed.
4. Members were largely content with the operating hours detailed in the report and did not agree to the extended hours as requested by the applicant in their late representation dated 13 May 2014. The committee requested that the hours of use of the roof top pool be amended to 09:00 – 22:00 hours.
5. Members raised further concerns regarding the detail of the draft S106 agreement produced by the applicant, which the committee unanimously determined to be insufficiently robust as to protect the

Item No.
5

interests of the City Council. Members noted that any draft legal agreement must secure provision of the replacement theatre fitted-out to shell and core prior to the occupation of the hotel and restaurant, in addition to the provision and retention of a publicly accessible curated sculpture gallery within the hotel to compensate for the loss of the photographers gallery and to ensure that the £600,000 being offered is only used to fit out the theatre.

6. The committee also agreed that the applicant must contribute towards S106 construction monitoring costs and pay CiL obligations.

The applicant has sought to address the issues as follows:

1. Theatre operator

The applicant's favoured theatre operator is 'PW (Peter Wilson) Productions Ltd' (A detailed brochure prepared by the theatre operator, and a testimonial letter by Julian Bird of the Society of London Theatre (SOLT) and the UK Theater Association (UKT) is included in the background papers).

The committee is asked to consider whether they agree that securing 'PW Productions Ltd' as a theatre operator, would offer sufficient reassurance that a theatre will be provided, and balances the loss of the existing D1 floorspace and increase in commercial floorspace without any residential uplift.

2. Rent

'PW Productions Ltd' has confirmed that the rent for the theatre space has been agreed in principle with the applicant 'Consolidated Developments' at a level which they consider satisfactory to ensure the viable operation of the theatre (A letter by PW Productions dated 30 March 2016 is included in background papers).

Committee previously resolved that the applicant will need to offer the new theatre at peppercorn rent in order to justify overturning the City Council's normal policy requirements to protect the existing D1 floorspace, and to provide residential floorspace or a financial contribution to the affordable housing fund in lieu of residential floorspace to address the uplift in commercial floorspace.

Committee is asked to consider whether the offer to provide the theatre at a rent level agreed between the applicant and 'PW Productions Ltd' is sufficient to justify overturning the City Council's normal policy requirements.

3. Amendments to rear elevation (height and bulk)

The height and bulk of the rear of the building has been reduced by introducing setbacks at fourth and fifth floor levels. The applicant has also submitted a further Sunlight/ Daylight Report which has assessed the impact of the development upon neighbouring properties in accordance with the BRE guidelines: Site Layout Planning for Daylight and Sunlight 2011.

Objections have been received from neighbours and the Covent Garden Community Association following re-consultation on the amended proposals. Objectors are still concerned about the height and bulk of the rear elevation and the impact upon residents within Sandringham Flats in terms of loss of daylight and sunlight.

Daylight

The BRE guidelines suggest that a 27% Vertical Sky Component (VSC) is indicative of a 'good level' of daylight. The BRE guidelines state that daylight levels may be adversely affected if the VSC measured at the centre of an existing main window is less than 27% and less than 0.8 times its former value. Should windows achieve sufficient levels of VSC they are seen as compliant in terms of daylight and no further tests are required.

The applicant's daylight assessment results show that the vast majority of the surrounding residential windows will continue to receive good levels of daylight in accordance with the BRE Guidelines criteria.

The only windows that fail are 3 x windows within block 27 – 41 Sandringham Flats, and 10 x windows within block 1 – 26 Sandringham Flats.

Where there are instances of changes to daylight in excess of the BRE guidelines (3 x windows within block 27 – 41 Sandringham Flats, and 10 x windows within block 1 – 26 Sandringham Flats), these occur where the existing light levels are so low already, that any reduction would show as being high in percentage terms but is unlikely to be noticeable to the occupant. These windows are already obstructed by overhanging balconies. The BRE guide acknowledges that existing windows with balconies above them typically receive less daylight as the balcony cuts out light from the top part of the sky and even a modest obstruction opposite may result in a large relative impact on VSC. The BRE guide goes on to explain that an additional calculation may be carried out assuming the balconies do not exist. If the windows meet the targets on this basis then this confirms that it is the balcony that prevents the targets from being met as opposed to an unreasonable level of obstruction caused by the development. The affected windows pass the VSC test when measured without the overhanging balconies. It is therefore considered that the proposed development satisfies the BRE daylight requirements.

Sunlight

The BRE guidelines states that sunlight availability may be adversely affected if the centre of the window:

- receives less than 25% of annual probable sunlight hours, or less than 5% of annual probable sunlight hours between 21 September and 21 March; and
- receives less than 0.8 times its former sunlight hours during either period; and
- has a reduction in sunlight received over the whole year greater than 4% of annual probable sunlight hours.

All neighbouring windows which face within 90 degrees of due south have been tested for direct sunlight. All windows pass both the total annual sunlight hours test and the winter sunlight hours test. The proposed development therefore satisfies the BRE direct sunlight requirements.

It is considered that the amendments to the rear elevation (reduction in height and bulk at fourth and fifth floor levels), addresses concerns regarding the impact upon residents in Sandringham Flats. The results of the Sunlight/ Daylight Report demonstrates that the development design satisfies all of the requirements set out in the BRE guide: Site Layout Planning for Daylight and Sunlight 2011.

Sense of enclosure

The new setbacks incorporated into the design of the upper floors between fourth and seventh floor levels would also help minimise the apparent increase in bulk of the development.

Given the significant distance between the application site and windows in Sandringham Flats, circa 40 metres, it is not considered that the development would result in any unacceptable sense of enclosure to these properties.

It is considered that the reduction in height and bulk of the rear has addressed the concerns raised by committee.

4. Hours

Committee is asked to consider whether the operating hours of the restaurant and theatre space bar detailed in the report are acceptable despite requests by the applicant to revisit and extend these hours.

Conditions 30 and 32 control hours of the ground floor restaurant, as well as the theatre space and theatre bar on the lower ground floor. Members were largely content with the operating hours detailed in the report and did not agree to the extended hours as previously requested by the applicant.

The applicant wishes to revisit these hours and extend the hours of the restaurant and theatre space/ bar. The applicant argues that the existing premises is not subject to planning control and the current license allows the theatre to remain open to midnight and the existing restaurant (Salvador and Amanda) until 3.30am. The applicant also states that the hours detailed in the report would restrict the operation of the site beyond that which facilitates a commercially viable operation.

The applicant requests, that the restaurant be allowed to open until 0100hrs Thursday to Saturday, and the theatre space and bar until 0200hrs Thursday to Saturday.

Despite this request, it is recommended that the restaurant, and theatre space and bar are subject to the hours detailed in the original report. Granting permission for this new development would give the City Council control over its operation and it is considered that this would help bring about some improvements in amenity terms, i.e. reduction in late night activity, when compared with the existing

situation.

Conditions 30 and 32 are recommended as set out in the original report/ detailed below:

Condition 30: Customers shall not be permitted within the restaurant premises before 0800hrs or after 0000hrs (midnight) Monday to Thursday, or before 0800hrs and 0030hrs Fridays to Sundays.

Condition 32: Customers shall not be permitted within the theatre premises before 0800hrs or after 0000hrs daily.

5. Draft s106

The applicant has produced a draft legal agreement which seeks to secure provision of the replacement theatre fitted-out to shell and core prior to occupation of the hotel and restaurant, in addition to the provision and retention of a publicly accessible curated sculpture gallery within the hotel to compensate for the loss of the photographer's gallery, and to ensure that the £600,000 being offered is only used to fit out the theatre.

The committee is asked to consider whether they agree the draft legal agreement is sufficiently robust to protect the interests of the city council (The draft legal agreement by Herbert Smith Freehills dated 02 March 2016 is included in the background papers).

6. s106 construction monitoring costs/ CiL obligations.

The committee agreed that the applicant must contribute towards s106 construction monitoring costs and pay CiL obligations. This is accepted by the applicant. It is recommended that the necessary contributions to ensure compliance with the Council's Code of Construction Practice, and to secure the monitoring expertise of the Council's Environmental Sciences Team, the latter of which controls noise, dust and vibration emanating from the site through a site specific SEMP, should be secured through a S106 legal agreement.

In summary, committee is asked to consider whether they agree the applicant has satisfactorily addressed the issues, raised by committee on 13 May 2014.

3. LOCATION PLAN

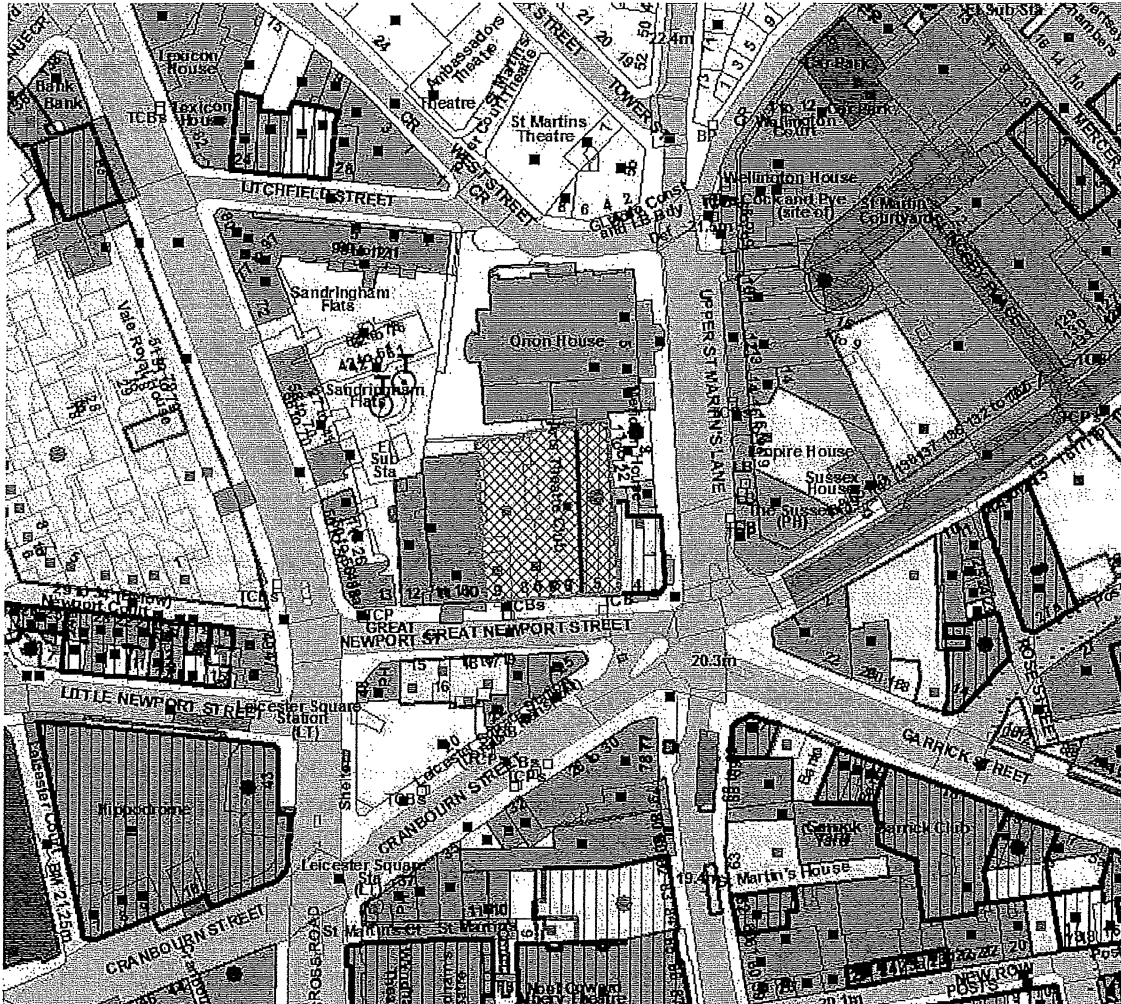

This production includes mapping data licensed from Ordnance Survey with the permission of the controller of Her Majesty's Stationary Office (C) Crown Copyright and /or database rights 2013.
 All rights reserved License Number LA 100019597

Item No.
5

4. PHOTOGRAPHS



5-9 Great Newport Street, London, WC2H 7JB

5. - CONSULTATIONS

ADDITIONAL REPRESENTATIONS RECEIVED FOLLOWING RE-CONSULTATION ON AMENDED DRAWINGS (REDUCTION IN HEIGHT AND BULK OF REAR ELEVATION AT 4TH AND 5TH FLOOR LEVELS)

COVENT GARDEN COMMUNITY ASSOCIATION

Raise objections and concerns on a number of issues:

Land use

- Concerns about long term viability of theatre and ability to ensure a minimum of at least 320 operational theatre days a year.
- Absence of fly-tower in replacement theatre will massively impact upon ability of theatre to stage productions and many theatre productions will no longer consider the theatre as a potential viable space.
- Proposals do not outweigh need to provide residential floorspace or a financial contribution to the affordable housing fund.

Amenity

- Adverse impact on daylight and sunlight levels to residents in Sandringham Flats.
- Noise and disturbance from proposed roof top pool, and late night entertainment uses.
- Conditions recommended to control hours and use as follows:
Restaurant and bar: Closing times no later than 11pm Sunday - Thursday and 12 midnight Fridays – Saturdays.
Roof top pool: 10pm closing time.
Bar: Limited to max 100 covers
Mechanical plant: noise conditions.

Highways

- Conditions recommended to control servicing and deliveries.

Other

- Lack of engagement from the applicant with local residents and stakeholders.

COVENT GARDEN AREA TRUST

No comment.

ADJOINING OWNERS/OCCUPIERS AND OTHER REPRESENTATIONS RECEIVED

No. Consulted: 192

Total No. of replies: 64

No. of objections: 64

No. in support: 0

66 objections (including a response on behalf of all residents and owners of Sandringham Flats, Charing Cross Road) received on some or all of the following grounds:

Amenity

- Loss of daylight and sunlight to flats, roof terraces and courtyards in Sandringham Flats.

Item No.
5

- Overlooking of neighbouring properties.
- Increased noise nuisance from plant machinery.
- Noise nuisance from pool and terrace.
- Noise and disturbance from entertainment uses.
- Impact on amenity from more intensive use not acceptable within stress area.
- Noise and disturbance from prolonged building works.

Land use

- Concerns about lack of contributions towards affordable housing fund.

Other

- Lack of engagement from the applicant and planners with local residents.

6. BACKGROUND PAPERS

**ADDITIONAL REPRESENTATIONS RECEIVED SINCE COMMITTEE ON 13 MAY 2014/
RE-CONSULTATION ON AMENDED DRAWINGS**

1. Minutes and report of the Director of Planning dated 13 May 2014 (including original background papers/ representations)
2. Letter from 'PW (Peter Wilson) Productions Ltd' dated 30 March 2016
3. Applicant's draft legal agreement by Herbert Smith Freehills dated 02 March 2016
4. Testimonial for Peter Wilson by Julian Bird of the Society of London Theatre (SOLT) and the UK Theatre Association (UKT) dated 19 January 2016
5. Brochure prepared by 'PW (Peter Wilson) Productions Ltd'
6. Letter from Covent Garden Community Association dated 14 January 2015
7. Response from Covent Garden Area Trust, dated 6 January 2015
8. Letter from occupier [REDACTED] dated 29 December 2014
9. Letter from occupier AKA Planning on behalf of residents and owners of [REDACTED] dated 12 January 2015
10. Letter from occupier of [REDACTED] dated 12 January 2015
11. Letter from occupier of [REDACTED] dated 11 January 2015
12. Letter from occupier of [REDACTED] dated 11 January 2015
13. Letter from occupier of [REDACTED] dated 11 January 2015
14. Letter from occupier of [REDACTED] dated 11 January 2015
15. Letter from occupier of [REDACTED] dated 11 January 2015
16. Letter from occupier of [REDACTED] dated 11 January 2015
17. Letter from occupier of [REDACTED] dated 11 January 2015
18. Letter from occupier of [REDACTED] dated 11 January 2015
19. Letter from occupier of [REDACTED] dated 11 January 2015
20. Letter from occupier of [REDACTED] dated 11 January 2015
21. Letter from occupier of [REDACTED] dated 11 January 2015
22. Letter from occupier of [REDACTED] dated 11 January 2015
23. Letter from occupier of [REDACTED] dated 11 January 2015
24. Letter from occupier of [REDACTED] dated 11 January 2015
25. Letter from occupier of [REDACTED] dated 11 January 2015
26. Letter from occupier of [REDACTED] dated 11 January 2015
27. Letter from occupier of [REDACTED] dated 11 January 2015
28. Letter from occupier of [REDACTED] dated 11 January 2015
29. Letter from occupier of [REDACTED] dated 11 January 2015

Item No.
5

(Please note: All the application drawings and other relevant documents and Background Papers are available to view on the Council's website)

IF YOU HAVE ANY QUERIES ABOUT THIS REPORT PLEASE CONTACT DAVID DORWARD ON 020 7641 2408 OR BY EMAIL AT ddorward@westminster.gov.uk

7. KEY DRAWINGS

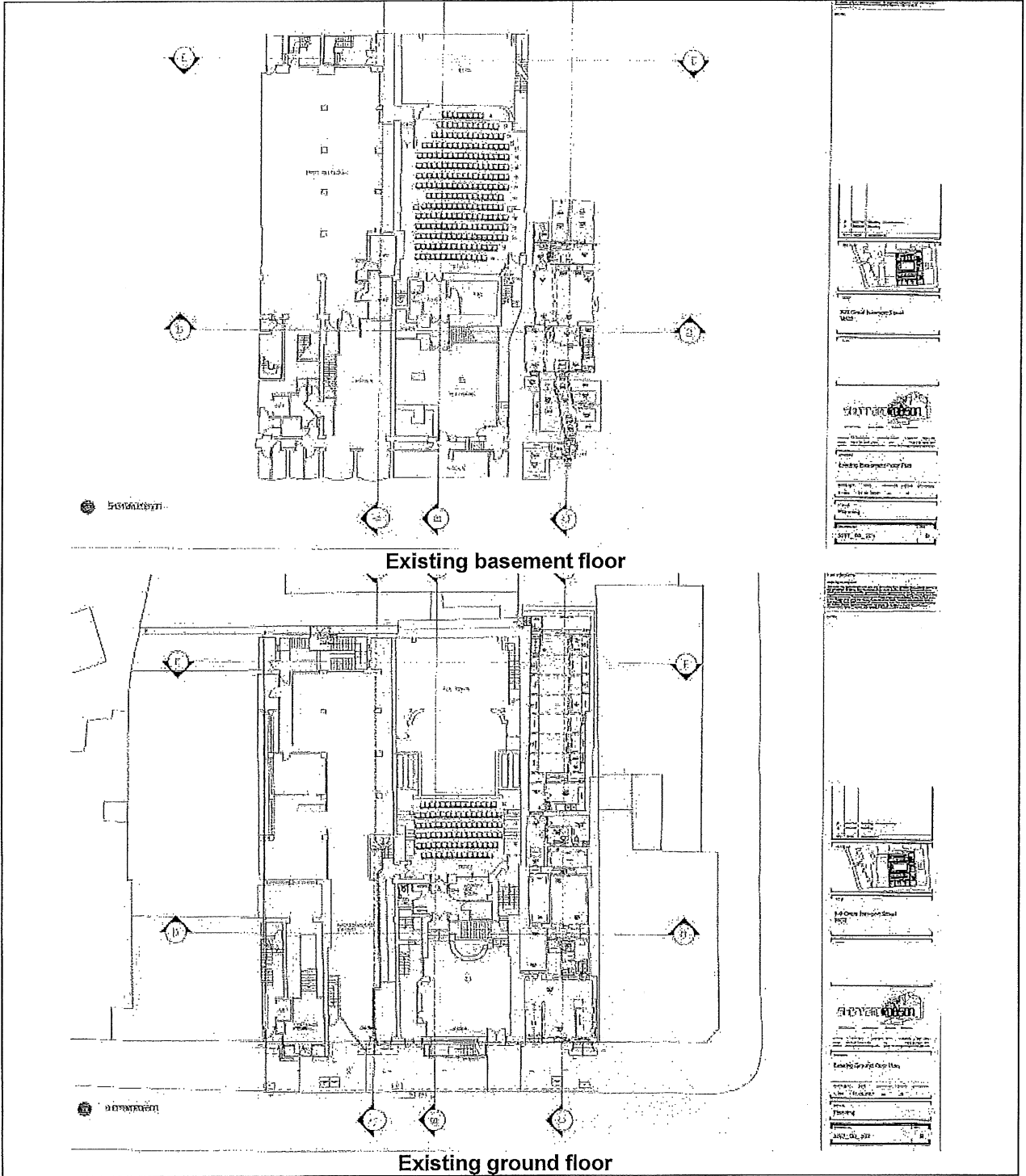

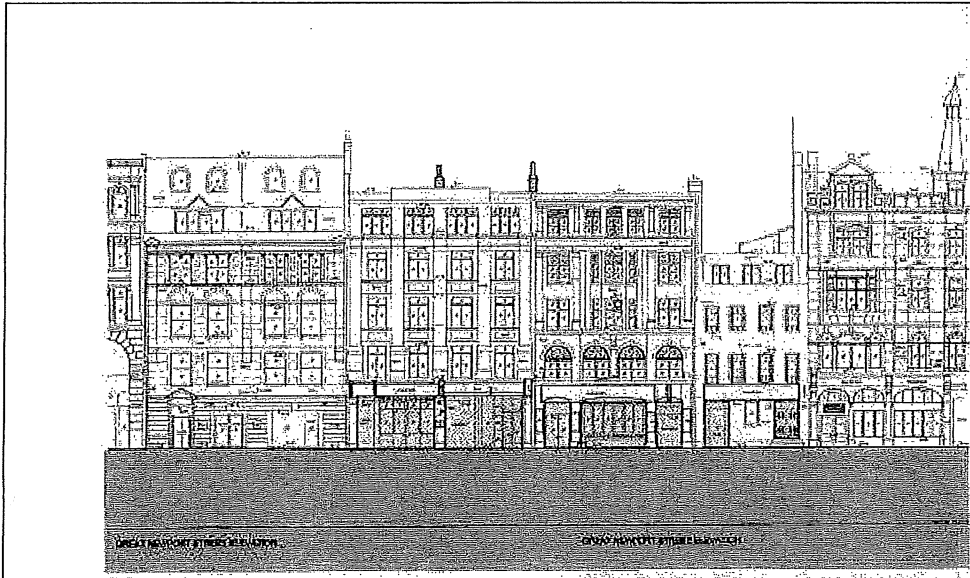

02/20/2018

Existing front elevation

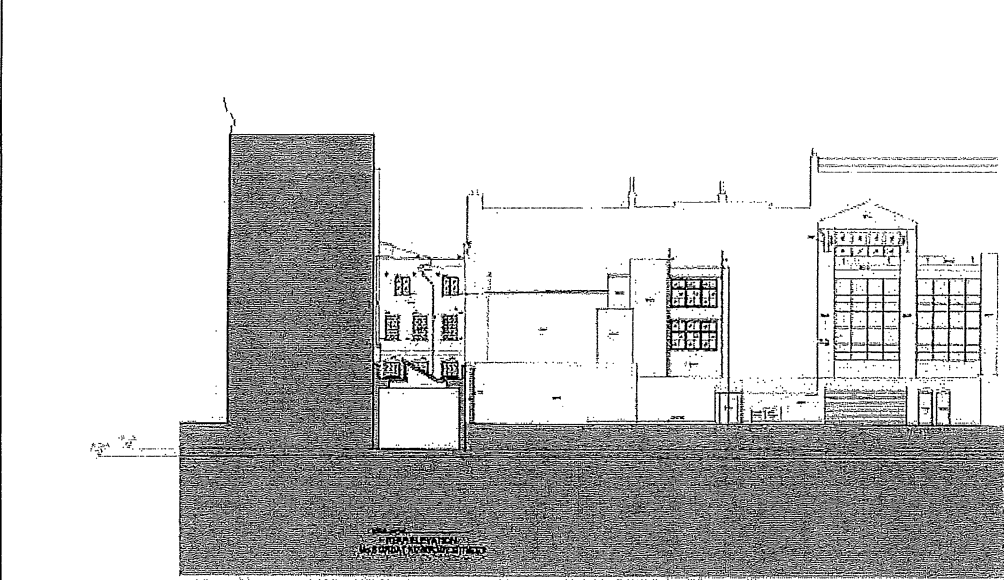

02/20/2018

Existing rear elevation

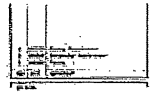

30 South Market Street
West



Project Name	30 South Market Street
Project Number	18000000000000000000
Project Location	West
Project Date	02/20/2018
Project Status	Existing
Project Type	Architectural
Project Scale	1/8" = 1'-0"
Project Author	02/20/2018

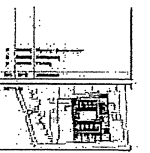

30 South Market Street
West



Project Name	30 South Market Street
Project Number	18000000000000000000
Project Location	West
Project Date	02/20/2018
Project Status	Existing
Project Type	Architectural
Project Scale	1/8" = 1'-0"
Project Author	02/20/2018

Item No.
5

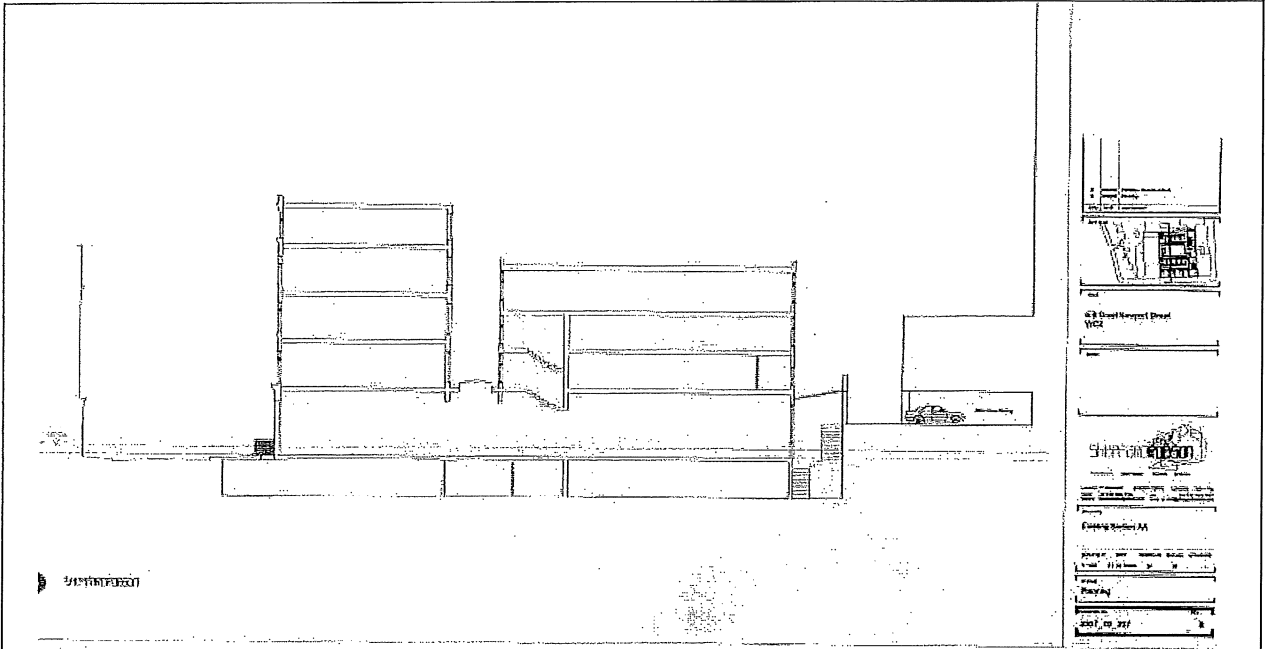

Existing long section AA

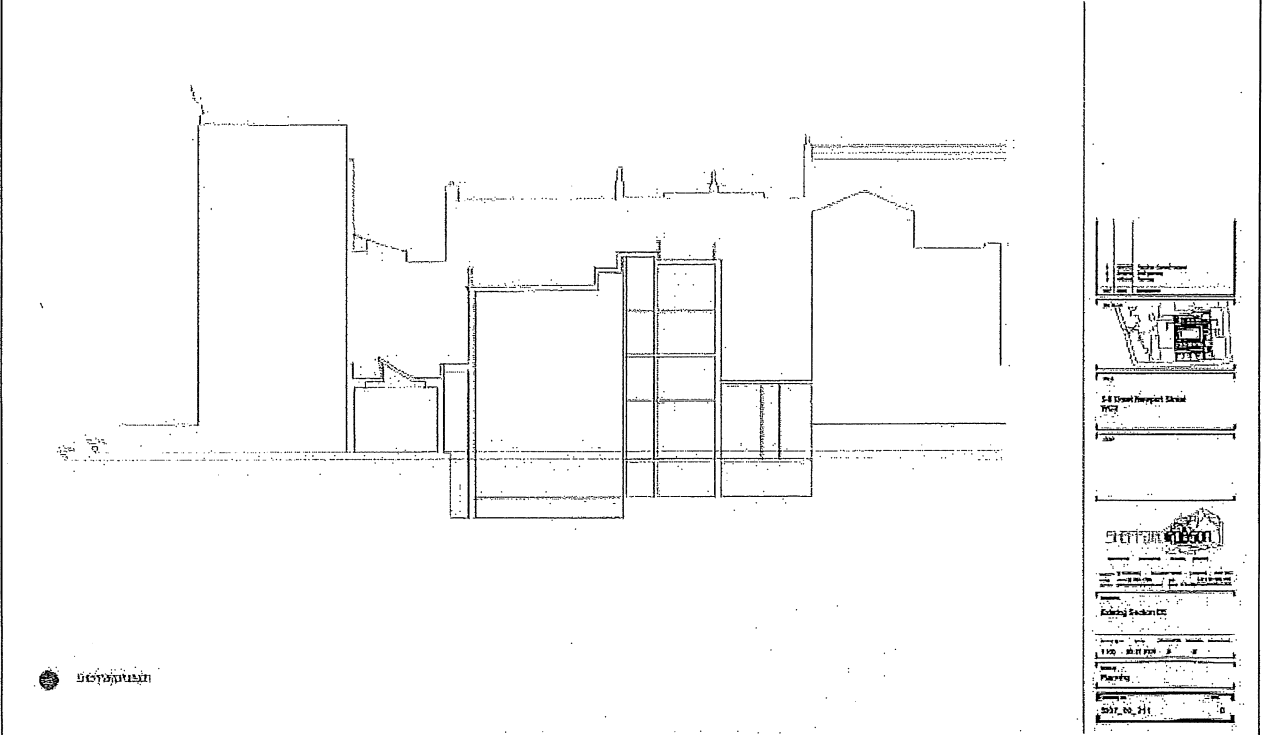

Existing cross section EE

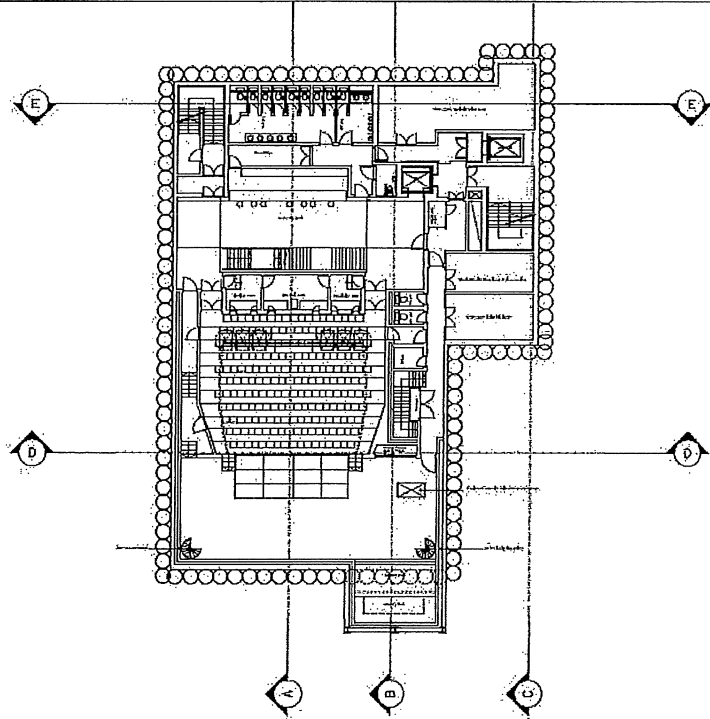

Proposed first basement floor

<p>REVISIONS</p> <table border="1"> <tr><th>No.</th><th>Description</th><th>Date</th></tr> <tr><td> </td><td> </td><td> </td></tr> <tr><td> </td><td> </td><td> </td></tr> <tr><td> </td><td> </td><td> </td></tr> </table>		No.	Description	Date									
No.	Description	Date											
<p>Scale: 1/8" = 1'-0"</p>													
<p>64-Cross Street, New York, NY 10013</p>													
<p style="text-align: center;">Sheppard Associates</p>													
<p>Architects</p>													
<p>Project: 100 Cross Street, New York, NY</p>													
<p>Client: 100 Cross Street, New York, NY</p>													
<p>Phase: 100 Cross Street, New York, NY</p>													
<p>Date: 10/15/2011</p>													

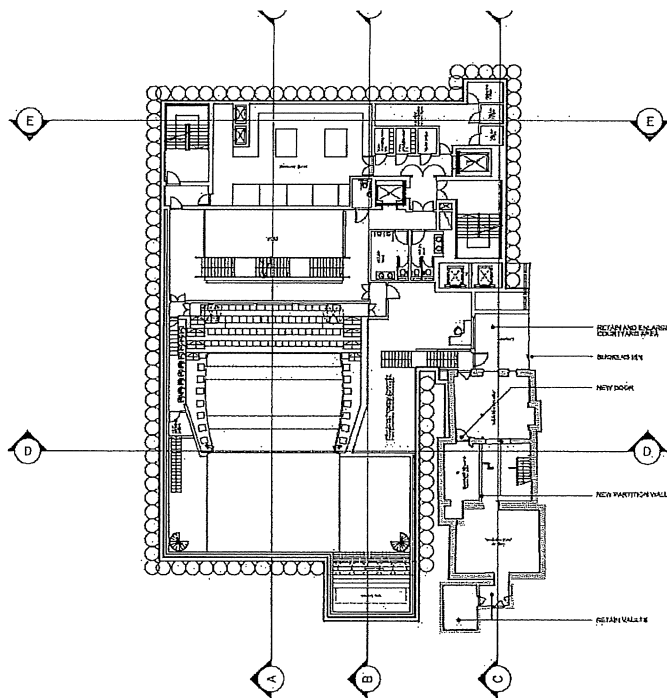

Proposed lower ground floor

<p>REVISIONS</p> <table border="1"> <tr><th>No.</th><th>Description</th><th>Date</th></tr> <tr><td> </td><td> </td><td> </td></tr> <tr><td> </td><td> </td><td> </td></tr> <tr><td> </td><td> </td><td> </td></tr> </table>		No.	Description	Date									
No.	Description	Date											
<p>Scale: 1/8" = 1'-0"</p>													
<p>64-Cross Street, New York, NY 10013</p>													
<p style="text-align: center;">Sheppard Associates</p>													
<p>Architects</p>													
<p>Project: 100 Cross Street, New York, NY</p>													
<p>Client: 100 Cross Street, New York, NY</p>													
<p>Phase: 100 Cross Street, New York, NY</p>													
<p>Date: 10/15/2011</p>													

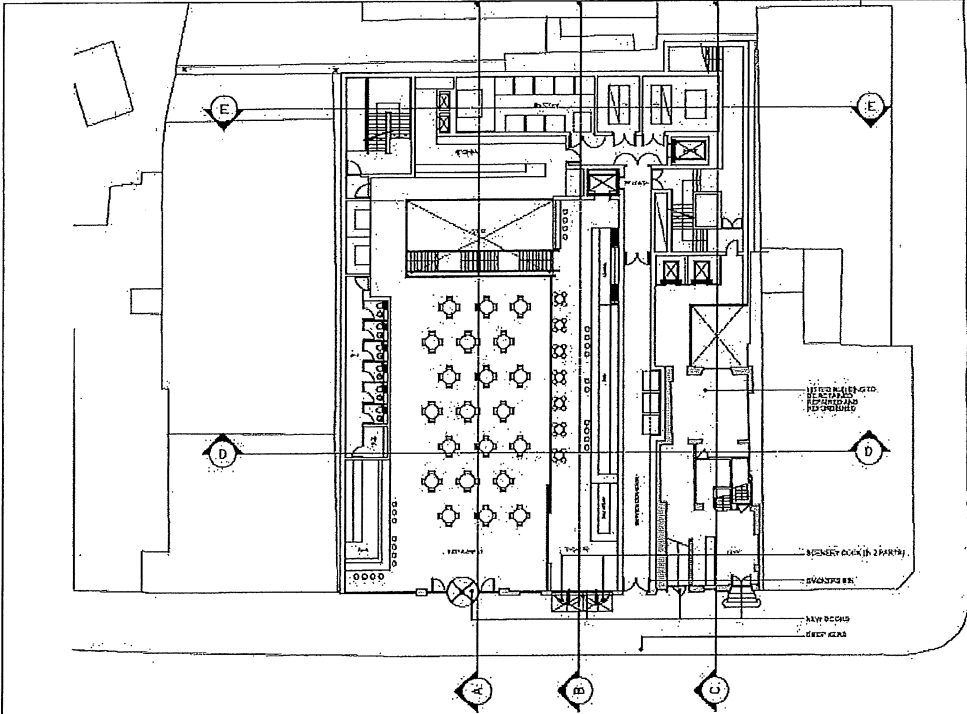

Proposed ground floor

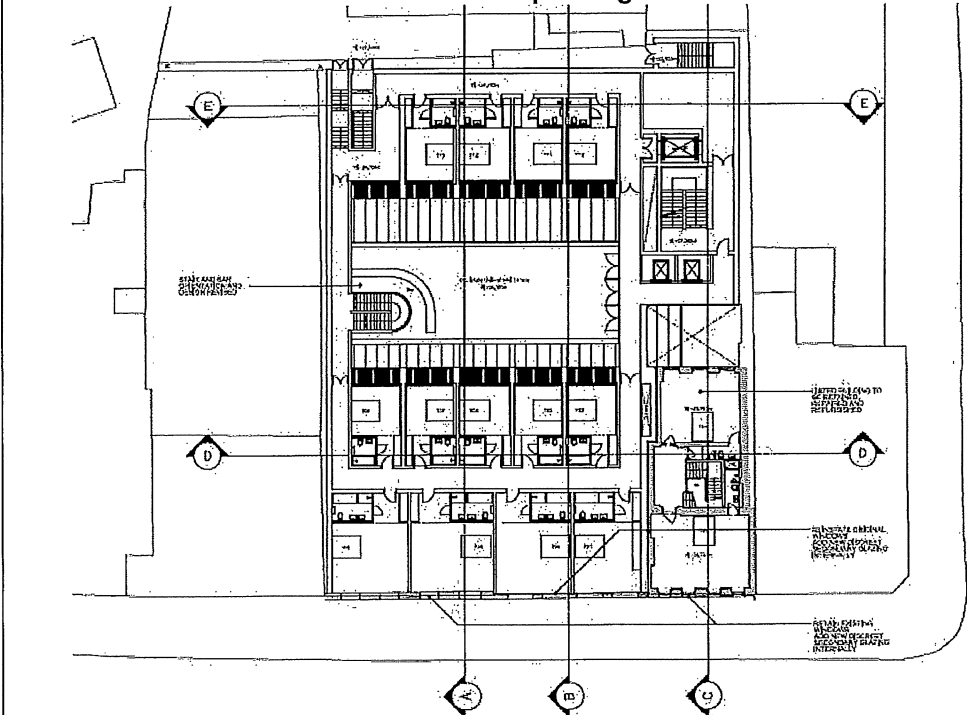

Proposed first floor

<p>REVISIONS</p> <table border="1"> <tr> <th>No.</th> <th>Description</th> <th>Date</th> </tr> <tr> <td> </td> <td> </td> <td> </td> </tr> <tr> <td> </td> <td> </td> <td> </td> </tr> </table>		No.	Description	Date						
No.	Description	Date								
<p>DATE: 10/10/2014</p> <p>BY: [Signature]</p>	<p>DATE: 10/10/2014</p> <p>BY: [Signature]</p>									
<p>Proposed Ground Floor Plan</p>										
<p>Scale: 1/4" = 1'-0"</p> <p>Project: [Project Name]</p> <p>Sheet: 5 of 10</p>										

<p>REVISIONS</p> <table border="1"> <tr> <th>No.</th> <th>Description</th> <th>Date</th> </tr> <tr> <td> </td> <td> </td> <td> </td> </tr> <tr> <td> </td> <td> </td> <td> </td> </tr> </table>		No.	Description	Date						
No.	Description	Date								
<p>DATE: 10/10/2014</p> <p>BY: [Signature]</p>	<p>DATE: 10/10/2014</p> <p>BY: [Signature]</p>									
<p>Proposed First Floor Plan</p>										
<p>Scale: 1/4" = 1'-0"</p> <p>Project: [Project Name]</p> <p>Sheet: 5 of 10</p>										

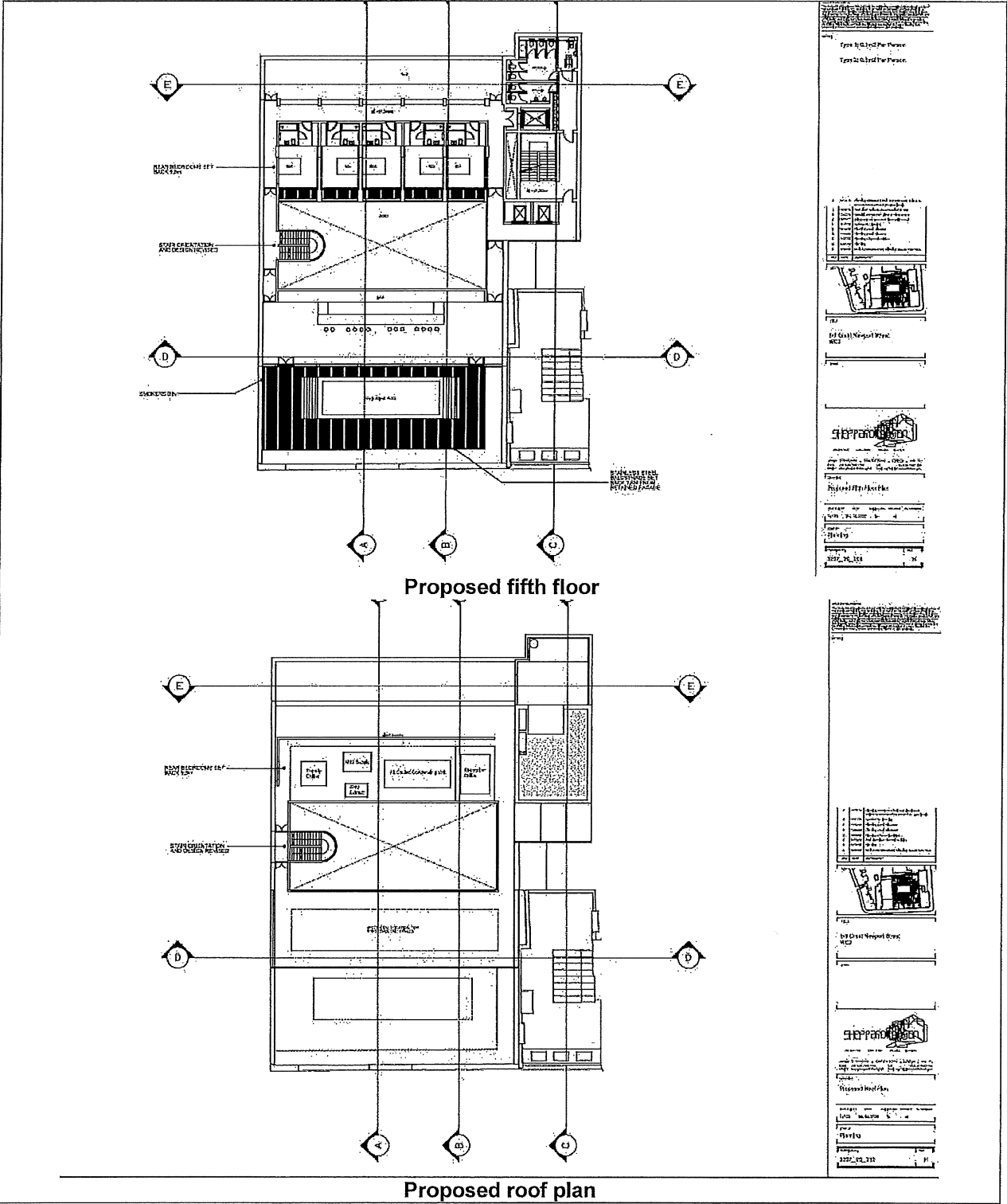

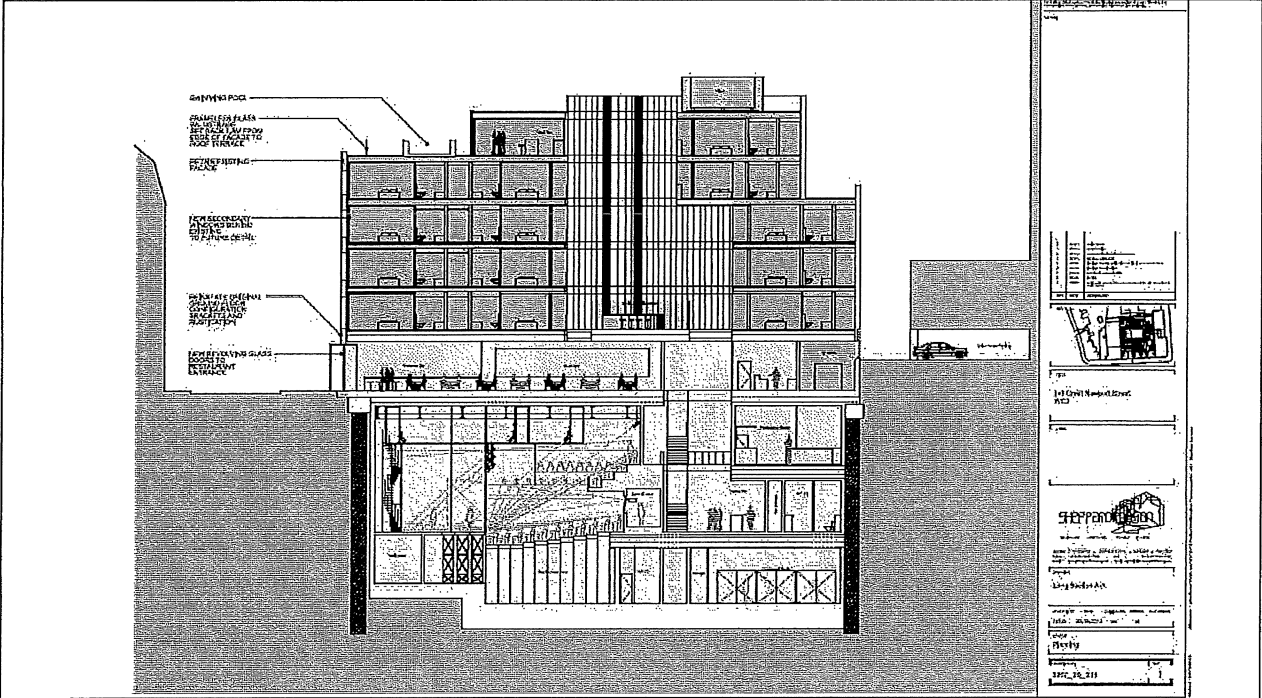

Proposed long section AA

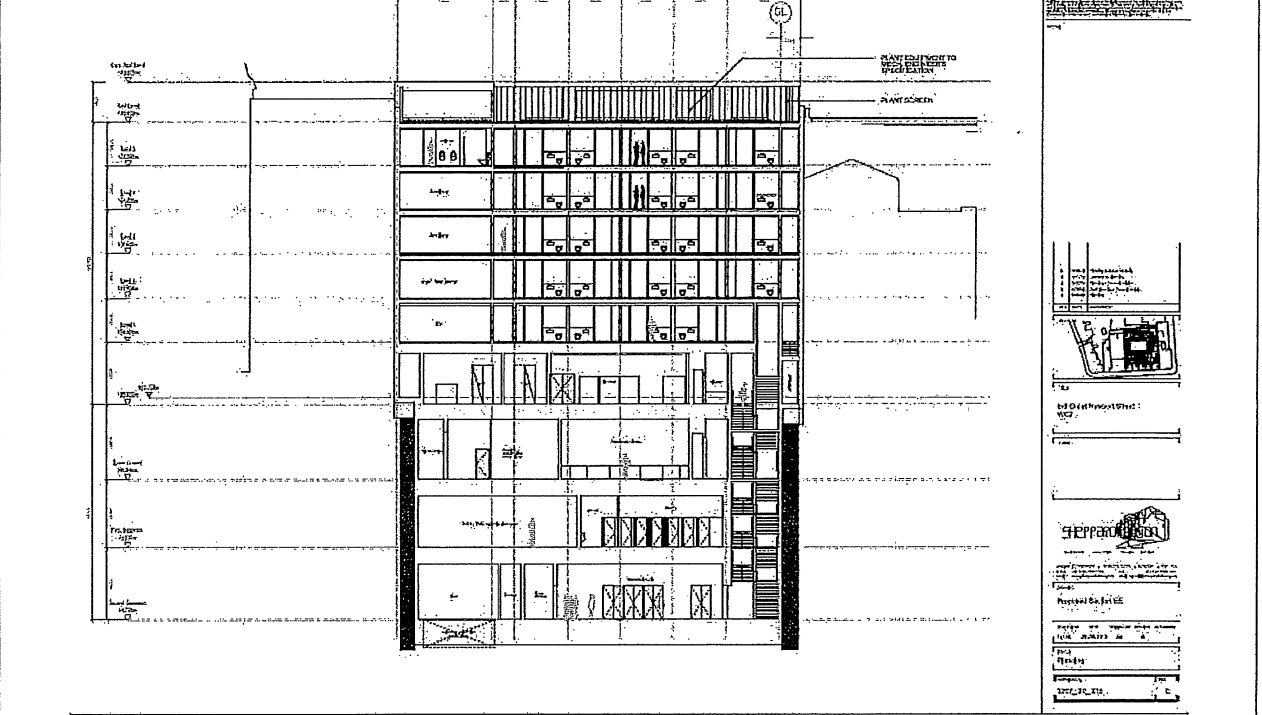

Existing cross section EE

Item No.
5

DRAFT DECISION LETTER

Address: 5-9 Great Newport Street, London, WC2H 7JB

Proposal: Demolition of Nos. 6-9 Great Newport Street behind retained front facades and demolition of rear addition to No. 5 Great Newport Street. Excavation and redevelopment to provide a building comprised of lower basement, basement, lower ground, ground and six upper floors, terraces, roof plant and alterations to front facade, providing a new auditorium and ancillary services in the form of a new flexible 322 seat theatre space and arts club venue along with rehearsal studio and ancillary facilities including bars at basement level 1 and ground floor level (sui generis), restaurant (Class A3) on the ground floor and part lower ground floors and a 66 bedroom hotel at part ground and first to sixth floor levels (across 5-9 Great Newport Street), associated hotel bar and sculpture gallery at first floor level and outdoor swimming pool, terrace and bar at fifth floor level.

Reference: 12/03930/FULL

Plan Nos: Location Plan, 3207_00_207 B, 208 D, 209 B, 210 B, 211 C, 214 A, Existing Front Elevations (unnumbered), 3207_20_101 C, 102 C, 103 C, 104 C, 105 C, 106 C, 107 C, 108 C, 109 D, 110 C, 111 C, 112 C, 113 B, 200 A, 201 E, 202 E, 203 I, 204 G, 205 E, 206 F, 207 E, 208 K, 209 K, 210 H, 211 J, 212 M, 213 M, 214 H, 215 E, 216 N, 218 J, 219 D, 220 C, Design and Access Statement dated April 2012, Design and Access Statement Addendum dated November 2013, Planning Statement dated April 2012, Letter from Turley Associates dated 17.12.2013, Report of Theatre Design Consultant Ian Albery dated 09.09.2013, Letter from Ian Albery dated 16.04.2014, Report of Anne Minors dated July 2012, Letter from Anne Minors dated 09.04.2014, Historic Buildings Architect's Report dated April 2008, Heritage Statement dated April 2012, Archaeological Desktop Assessment dated April 2008, Environmental and Planning Noise Report dated 05.04.2012, Daylight and Sunlight Report dated 23.03.2012, Sustainability and Energy Report dated April 2012, Transport Assessment dated 03.04.2012. For information purposes only - Excavation and Facade Retention Feasibility Report dated April 2008, Structural Engineers Concepts Report dated 30.09.2013, Daylight and Sunlight Study dated 08 December 2014.

Case Officer: David Dorward

Direct Tel. No. 020 7641 2408

Recommended Condition(s) and Reason(s):

- 1 The development hereby permitted shall be carried out in accordance with the drawings and other documents listed on this decision letter, and any drawings approved subsequently by the City Council as local planning authority pursuant to any conditions on this decision letter.

Reason:

For the avoidance of doubt and in the interests of proper planning.

- 2 Except for basement excavation work, you must carry out any building work which can be heard at the boundary of the site only:

- * between 08.00 and 18.00 Monday to Friday,;
- * between 08.00 and 13.00 on Saturday; and,
- * not at all on Sundays, bank holidays and public holidays.

You must carry out basement excavation work only:

- * between 08.00 and 18.00 Monday to Friday; and,
- * not at all on Saturdays, Sundays, bank holidays and public holidays.

Noisy work must not take place outside these hours. (C11BA)

Reason:

To protect the environment of neighbouring residents. This is as set out in S29 and S32 of Westminster's City Plan: Strategic Policies adopted November 2013 and ENV 6 of our Unitary Development Plan that we adopted in January 2007. (R11AC)

- 3 (1) Where noise emitted from the proposed plant and machinery will not contain tones or will not be intermittent, the 'A' weighted sound pressure level from the plant and machinery (including non-emergency auxiliary plant and generators) hereby permitted, when operating at its noisiest, shall not at any time exceed a value of 10 dB below the minimum external background noise, at a point 1 metre outside any window of any residential and other noise sensitive property, unless and until a fixed maximum noise level is approved by the City Council. The background level should be expressed in terms of the lowest LA90, 15 mins during the proposed hours of operation. The plant-specific noise level should be expressed as LAeqTm, and shall be representative of the plant operating at its maximum., , (2) Where noise emitted from the proposed plant and machinery will contain tones or will be intermittent, the 'A' weighted sound pressure level from the plant and machinery (including non-emergency auxiliary plant and generators) hereby permitted, when operating at its noisiest, shall not at any time exceed a value of 15 dB below the minimum external background noise, at a point 1 metre outside any window of any residential and other noise sensitive property, unless and until a fixed maximum noise level is approved by the City Council. The background level should be expressed in terms of the lowest LA90, 15 mins during the proposed hours of operation. The plant-specific noise level should be expressed as LAeqTm, and shall be representative of the plant operating at its maximum., , (3) Following installation of the plant and equipment, you may apply in writing to the City Council for a fixed maximum noise level to be approved. This is to be done by submitting a further noise report confirming previous details and subsequent measurement data of the installed plant, including a proposed fixed noise level for approval by the City Council. Your submission of a noise report must include:, (a) A schedule of all plant and equipment that formed part of this application;, (b) Locations of the plant and machinery and associated: ducting; attenuation and damping equipment; (c) Manufacturer

specifications of sound emissions in octave or third octave detail; (d) The location of most affected noise sensitive receptor location and the most affected window of it; (e) Distances between plant & equipment and receptor location/s and any mitigating features that may attenuate the sound level received at the most affected receptor location; (f) Measurements of existing LA90, 15 mins levels recorded one metre outside and in front of the window referred to in (d) above (or a suitable representative position), at times when background noise is at its lowest during hours when the plant and equipment will operate. This acoustic survey to be conducted in conformity to BS 7445 in respect of measurement methodology and procedures; (g) The lowest existing LA90, 15 mins measurement recorded under (f) above; (h) Measurement evidence and any calculations demonstrating that plant and equipment complies with the planning condition; (i) The proposed maximum noise level to be emitted by the plant and equipment.

Reason:

Because existing external ambient noise levels exceed WHO Guideline Levels, and as set out in ENV 6 (1), (6) and (8) and ENV 7 (A)(1) of our Unitary Development Plan that we adopted in January 2007, so that the noise environment of people in noise sensitive properties is protected, including the intrusiveness of tonal and impulsive sounds; and as set out in S32 of Westminster's City Plan: Strategic Policies adopted November 2013, by contributing to reducing excessive ambient noise levels. Part (3) is included so that applicants may ask subsequently for a fixed maximum noise level to be approved in case ambient noise levels reduce at any time after implementation of the planning permission.

- 4 No vibration shall be transmitted to adjoining or other premises and structures through the building structure and fabric of this development as to cause a vibration dose value of greater than 0.4m/s (1.75) 16 hour day-time nor 0.26 m/s (1.75) 8 hour night-time as defined by BS 6472 (2008) in any part of a residential and other noise sensitive property.

Reason:

As set out in ENV6 (2) and (6) of our Unitary Development Plan that we adopted in January 2007, to ensure that the development is designed to prevent structural transmission of noise or vibration.

- 5 You must apply to us for approval of details of a supplementary acoustic report demonstrating that the plant will comply with the Council's noise criteria as set out in Condition 3 of this permission. You must not start work on this part of the development until we have approved what you have sent us.

Reason:

Because existing external ambient noise levels exceed WHO Guideline Levels, and as set out in ENV 6 (1), (6) and (8) and ENV 7 (A)(1) of our Unitary Development Plan that we adopted in January 2007, so that the noise environment of people in noise sensitive properties is protected, including the intrusiveness of tonal and impulsive sounds; and as set out in S32 of Westminster's City Plan: Strategic Policies adopted November 2013, by contributing to reducing excessive

Item No.
5

ambient noise levels.

6

Before anyone moves into the property, you must provide the separate stores for waste and materials for recycling shown on drawing number 3207_20_203 Rev i. You must clearly mark them and make them available at all times to everyone using the uses hereby approved. (C14FB)

Reason:

To protect the environment and provide suitable storage for waste as set out in S44 of Westminster's City Plan: Strategic Policies adopted November 2013 and ENV 12 of our Unitary Development Plan that we adopted in January 2007. (R14BD)

- 7 You must hang all doors or gates so that they do not open over or across the road or pavement. (C24AA)

Reason:

In the interests of public safety and to avoid blocking the road as set out in S41 of Westminster's City Plan: Strategic Policies adopted November 2013 and TRANS 2 and TRANS 3 of our Unitary Development Plan that we adopted in January 2007. (R24AC)

- 8 The development hereby permitted shall not be commenced until detailed design and method statements (in consultation with London Underground) for all of the foundations, basement and ground floor structures, or for any other structures below ground level, including piling (temporary and permanent), have been submitted to and approved in writing by the local planning authority which:

- provide details on all structures;
- accommodate the location of the existing London Underground structures and tunnels;
- accommodate ground movement arising from the construction thereof; and,
- mitigate the effects of noise and vibration arising from the adjoining operations within the structures and tunnels.

The development shall thereafter be carried out in all respects in accordance with the approved design and method statements, and all structures and works comprised within the development hereby permitted which are required by the approved design statements in order to procure the matters mentioned in paragraphs of this condition shall be completed, in their entirety, before any part of the building hereby permitted is occupied.

Reason:

To ensure that the development does not impact on existing London Underground transport infrastructure, in accordance with London Plan policy 3C.4 and 'Land for Transport Functions'

Supplementary Planning Guidance.

- 9 **Pre Commencement Condition.** You must apply to us for approval of a detailed design and method statement relating to the foundations and all new ground work. You must not start any construction work until we have approved what you have sent us. You must then carry out the work according to the approved design and method statement. (C32AB)

Reason:

To avoid damage to any archaeological remains on site as set out in S25 of Westminster's City Plan: Strategic Policies adopted November 2013 and DES 11 of our Unitary Development Plan that we adopted in January 2007. (R32AC)

- 10 **Pre Commencement Condition.**
- (a) You must apply to us for approval of a written scheme of investigation for a programme of archaeological work. This must include details of the suitably qualified person or organisation that will carry out the archaeological work. You must not start work until we have approved what you have sent us.
- (b) You must then carry out the archaeological work and development according to this approved scheme. You must produce a written report of the investigation and findings, showing that you have carried out the archaeological work and development according to the approved scheme. You must send copies of the written report of the investigation and findings to us, to Historic England, and to the Greater London Sites and Monuments Record, 1 Waterhouse Square, 138-142 Holborn, London EC1N 2ST.
- (c) You must not use any part of the new building until we have confirmed that you have carried out the archaeological fieldwork and development according to this approved scheme. (C32BC)

Reason:

To protect the archaeological heritage of the City of Westminster as set out in S25 of Westminster's City Plan: Strategic Policies adopted November 2013 and DES 11 of our Unitary Development Plan that we adopted in January 2007. (R32BC)

- 11 No works of demolition authorised by this permission shall take place until the applicant has implemented a programme of building recording and analysis of the existing Arts Theatre by person or body approved by the Council as local planning authority. This programme shall be in accordance with a written scheme which has been submitted by the applicant and approved by the local planning authority advised by the Theatres Trust. The recording shall then be carried out according to the written scheme and no demolition work shall be carried out until the recording and analysis report has been received and approved by the City Council advised by the Theatres Trust.

Reason:

To ensure that the history of the site is recorded as set out in DES 11 of the 2007 UDP.

- 12 You must apply to us for approval of an operational management plan in relation to the hotel, restaurant and theatre. This should include details to show how you will control the use of the rooftop pool and terrace and how you will prevent customers who are leaving the buildings from causing nuisance for people in the area, including people who live in nearby buildings. You must not start the hotel, restaurant and/or theatre use until we have approved what you have sent us. You must then carry out the measures included in the management plan at all times that the hotel, restaurant and/or theatre is in use.

Reason:

To make sure that the use will not cause nuisance for people in the area. This is as set out in S24, S29 and S32 of Westminster's City Plan: Strategic Policies adopted November 2013 and TACE 6 and 8 and ENV 6 of our Unitary Development Plan that we adopted in January 2007. (R05GB)

- 13 No development shall take place, including any works of demolition, until a construction management plan for the proposed development has been submitted to and approved in writing by the City Council as local planning authority. The plan must include the following details (where appropriate):

- (i) a construction programme including a 24 hour emergency contact number;
- (ii) parking of vehicles of site operatives and visitors (including measures taken to ensure satisfactory access and movement for existing occupiers of neighbouring properties during construction);
- (iii) locations for loading/unloading and storage of plant and materials used in constructing the development;
- (iv) erection and maintenance of security hoardings (including decorative displays and facilities for public viewing, where appropriate);
- (v) wheel washing facilities and measures to control the emission of dust and dirt during construction; and
- (vi) a scheme for recycling/disposing of waste resulting from demolition and construction works.

You must not start work until we have approved what you have sent us. You must then carry out the development in accordance with the approved details. (C21MB)

Reason:

To protect the environment of residents and the area generally as set out in S29 of Westminster's City Plan: Strategic Policies adopted November 2013 and TRANS 23, ENV 5 and ENV 6 of our Unitary Development Plan that we adopted in January 2007.

- 14 The restaurant area shall be restricted to the area shown on the approved drawings and shall

Item No.
5

contain no more than 100 covers.

Reason:

We cannot grant planning permission for unrestricted use in this case because it would not meet TACE 8 of our Unitary Development Plan that we adopted in January 2007. (R05AB)

- 15 No customer, hotel resident or guest shall be permitted onto the rooftop terrace and pool area before 0800 or after 2200 each day.

Reason:

To protect the environment of people in neighbouring properties as set out in S24, S29 and S32 of Westminster's City Plan: Strategic Policies adopted November 2013 and ENV 6, ENV 7 and TACE 2 of our Unitary Development Plan that we adopted in January 2007. (R12AC)

- 16 All new work to the outside of the building must match existing original work in terms of the choice of materials, method of construction and finished appearance. This applies unless differences are shown on the drawings we have approved or are required by conditions to this permission. (C26AA)

Reason:

To make sure that the appearance of the building is suitable and that it contributes to the character and appearance of this part of the Covent Garden Conservation Area. This is as set out in S25 and S28 of Westminster's City Plan: Strategic Policies adopted November 2013 and DES 1 and DES 5 or DES 6 or both and paras 10.108 to 10.128 of our Unitary Development Plan that we adopted in January 2007. (R26BE)

- 17 You must apply to us for approval of details of the following parts of the development with detailed drawings at a scale of 1:10 and full size details –

- (i) all new windows and external doors,
- (ii) new canopy over theatre entrance,
- (iii) plant screen at roof level,
- (iv) all new shopfronts,

You must not start any work on these parts of the development until we have approved what you have sent us. You must then carry out the work according to these approved drawings. (C26DB)

Reason:

To make sure that the appearance of the building is suitable and that it contributes to the character and appearance of this part of the Covent Garden Conservation Area. This is as set

Item No.
5

out in S25 and S28 of Westminster's City Plan: Strategic Policies adopted November 2013 and DES 1 and DES 5 or DES 6 or both and paras 10.108 to 10.128 of our Unitary Development Plan that we adopted in January 2007. (R26BE)

- 18 You must apply to us for approval of a sample panel of brickwork which shows the colour, texture, face bond and pointing. You must not start work on this part of the development until we have approved what you have sent us. You must then carry out the work according to the approved sample. (C27DB)

Reason:

To make sure that the appearance of the building is suitable and that it contributes to the character and appearance of this part of the Covent Garden Conservation Area. This is as set out in S25 and S28 of Westminster's City Plan: Strategic Policies adopted November 2013 and DES 1 and DES 5 or DES 6 or both and paras 10.108 to 10.128 of our Unitary Development Plan that we adopted in January 2007. (R26BE)

- 19 You must not put any machinery or associated equipment, ducts, tanks, satellite or radio aerials on the roof, except those shown on the approved drawings. (C26PA)

Reason:

To make sure that the appearance of the building is suitable and that it contributes to the character and appearance of this part of the Covent Garden Conservation Area. This is as set out in S25 and S28 of Westminster's City Plan: Strategic Policies adopted November 2013 and DES 1 and DES 5 or DES 6 or both and paras 10.108 to 10.128 of our Unitary Development Plan that we adopted in January 2007. (R26BE)

- 20 You must apply to us for approval of samples of the facing materials you will use, including glazing, and elevations and roof plans annotated to show where the materials are to be located. You must not start any work on these parts of the development until we have approved what you have sent us. You must then carry out the work using the approved materials. (C26BC)

Reason:

To make sure that the appearance of the building is suitable and that it contributes to the character and appearance of this part of the Covent Garden Conservation Area. This is as set out in S25 and S28 of Westminster's City Plan: Strategic Policies adopted November 2013 and DES 1 and DES 5 or DES 6 or both and paras 10.108 to 10.128 of our Unitary Development Plan that we adopted in January 2007. (R26BE)

- 21 The design and structure of the development shall be of such a standard that it will protect

Item No.
5

residents within the same building or in adjoining buildings from noise and vibration from the development, so that they are not exposed to noise levels indoors of more than 35 dB LAeq 16 hrs daytime and of more than 30 dB LAeq 8 hrs in bedrooms at night.

Reason:

As set out in ENV6 of our Unitary Development Plan that we adopted in January 2007, and the related Policy Application at section 9.76, in order to ensure that design, structure and acoustic insulation of the development will provide sufficient protection for residents of the same or adjoining buildings from noise and vibration from elsewhere in the development.

- 22 You must put a copy of this planning permission and all its conditions at street level outside the building for as long as the work continues on site. You must highlight on the copy of the planning permission any condition that restricts the hours of building work. (C21KA)

Reason:

To make sure people in neighbouring properties are fully aware of the conditions and to protect their rights and safety. (R21GA)

- 23 You must apply to us for approval of detailed drawings showing the following alteration(s) to the scheme:

- All new rooftop balustrades to be made of black painted metal.

You must not start on these parts of the work until we have approved what you have sent us. You must then carry out the work according to the approved drawings. (C26UB)

Reason:

To make sure that the appearance of the building is suitable and that it contributes to the character and appearance of this part of the Covent Garden Conservation Area. This is as set out in S25 and S28 of Westminster's City Plan: Strategic Policies adopted November 2013 and DES 1 and DES 5 or DES 6 or both and paras 10.108 to 10.128 of our Unitary Development Plan that we adopted in January 2007. (R26BE)

- 24 **Pre Commencement Condition.** You must apply to us for approval of detailed drawings showing how you will support and protect the parts of the building which are to be kept during building work. You must not start work until we have approved what you have sent us. You must then carry out the work according to these drawings. (C28AB)

Reason:

To protect the parts of the building which are to be preserved during building work. (R28AA)

Item No.
5

- 25 You must apply to us for approval of a Servicing Management Plan, which includes details of how the hotel, restaurant and theatre will be serviced, including details proposing the hours of servicing for each use. You must not occupy the hotel or restaurant until we have approved what you have sent us. Thereafter you must then manage the servicing in accordance with the Servicing Management Plan that we approve, unless we agree an alternative Servicing Management Plan in writing.

Reason:

To avoid blocking the surrounding streets and to protect the environment of people in neighbouring properties as set out in S42 of Westminster's City Plan: Strategic Policies adopted November 2013 and STRA 25, TRANS 20 and TRANS 21 of our Unitary Development Plan that we adopted in January 2007. (R23AC)

- 26 The development shall achieve an 'Outstanding' rating under the BREEAM 2011 New Construction Assessment Scheme (or any such national measure of sustainability for design that replaces that scheme of the same standard).

Reason:

To make sure that the development affects the environment as little as possible, as set out in S28 or S40, or both, of Westminster's City Plan: Strategic Policies adopted November 2013. (R44BC)

- 27 The BREEAM assessment required by condition 26 must be completed and certified by the Building Research Establishment and a copy of the certificate detailing the award score for the building shall be submitted to us within 3 months of first occupation. In the event that this fails to meet the proposed 'Outstanding' rating (or equivalent) a full schedule of costs and works to achieve such a rating shall be submitted at the same time. In the event that the Council considers it is practicable and reasonable to require the implementation of these remedial works to achieve such a rating such measures, or alternatives to secure off site remedial actions, shall be carried out within six months of any such determination.

Reason:

To make sure that the development affects the environment as little as possible, as set out in S28 or S40, or both, of Westminster's City Plan: Strategic Policies adopted November 2013. (R44BC)

- 28 You must not allow more than 120 customers into the hotel bar at first floor level at any one time. The first floor bar area is the part of the property annotated on approved drawing no.

Item No.
5

3207_20_204 F as the 'Sculpture Gallery/Hotel Terrace'.

Reason:

To make sure that the use will not cause nuisance for people in the area. This is as set out in S24, S29 and S32 of Westminster's City Plan: Strategic Policies adopted November 2013 and TACE 2 and ENV 6 of our Unitary Development Plan that we adopted in January 2007. (R05GB)

29

You must not allow a total of more than 100 customers into the hotel bar and terrace at fifth floor level at any one time. The fifth floor bar area and external terrace is the part of the property shown on approved drawing no. 3207_20_208 H.

Reason:

To make sure that the use will not cause nuisance for people in the area. This is as set out in S24, S29 and S32 of Westminster's City Plan: Strategic Policies adopted November 2013 and TACE 2 and ENV 6 of our Unitary Development Plan that we adopted in January 2007. (R05GB)

- 30 Customers shall not be permitted within the restaurant premises before 0800hrs or after 0000hrs (midnight) Monday to Thursday, or before 0800hrs and 0030hrs Fridays to Sundays.

Reason:

To make sure that the use will not cause nuisance for people in the area. This is as set out in S24, S29 and S32 of Westminster's City Plan: Strategic Policies adopted November 2013 and TACE 10 and ENV 6 of our Unitary Development Plan that we adopted in January 2007. (R05GB)

- 31 The first and fifth floor bar areas within the hotel hereby approved shall not be open to customers (other than hotel residents (those staying overnight at the hotel)) between the following times: 0900hrs to 0000hrs (midnight) Monday to Thursday; and 0900hrs to 0030hrs Friday to Sunday.

Reason:

To make sure that the use will not cause nuisance for people in the area. This is as set out in S24, S29 and S32 of Westminster's City Plan: Strategic Policies adopted November 2013 and TACE TACE 2 and ENV 6 of our Unitary Development Plan that we adopted in January 2007. (R05GB)

- 32 Customers shall not be permitted within the theatre premises before 0800hrs or after 0000hrs daily.

Item No.
5

Reason:

To make sure that the use will not cause nuisance for people in the area. This is as set out in S24, S29 and S32 of Westminster's City Plan: Strategic Policies adopted November 2013 and TACE 6 and ENV 6 of our Unitary Development Plan that we adopted in January 2007. (R05GB)

Informative(s):

- 1 In dealing with this application the City Council has implemented the requirement in the National Planning Policy Framework to work with the applicant in a positive and proactive way. We have made available detailed advice in the form of our statutory policies in Westminster's City Plan: Strategic Policies adopted November 2013, Unitary Development Plan, Supplementary Planning documents, planning briefs and other informal written guidance, as well as offering a full pre application advice service, in order to ensure that applicant has been given every opportunity to submit an application which is likely to be considered favourably. In addition, where appropriate, further guidance was offered to the applicant at the validation stage.
- 2 The applicant is advised to contact London Underground Infrastructure Protection in advance of preparation of final design and associated method statements, in particular with regard to; demolition; excavation; construction methods; security; boundary treatment; safety barriers; landscaping and lighting.
- 3 Please contact our District Surveyors' Services to discuss how you can design for the inclusion of disabled people. Email: districtsurveyors@westminster.gov.uk. Phone 020 7641 7240 or 020 7641 7230. If you make a further planning application or a building regulations application which relates solely to providing access or facilities for people with disabilities, our normal planning and building control fees do not apply. , The Equality and Human Rights Commission has a range of publications to assist you, see www.equalityhumanrights.com. The Centre for Accessible Environment's 'Designing for Accessibility', 2004, price £22.50 is a useful guide, visit www.cae.org.uk. , If you are building new homes you must provide features which make them suitable for people with disabilities. For advice see www.habinteg.org.uk , It is your responsibility under the law to provide good access to your buildings. An appropriate and complete Access Statement as one of the documents on hand-over, will provide you and the end user with the basis of a defence should an access issue be raised under the Disability Discrimination Acts.
- 4 Please make sure that the street number and building name (if applicable) are clearly displayed on the building. This is a condition of the London Building Acts (Amendments) Act 1939, and there are regulations that specify the exact requirements. (I54AA)
- 5 The development will result in changes to road access points. Any new threshold levels in the building must be suitable for the levels of neighbouring roads. If you do not plan to make changes to the road and pavement you need to send us a drawing to show the threshold and

Item No.
5

existing road levels at each access point., , If you need to change the level of the road, you must apply to our Highways section at least eight weeks before you start work. You will need to provide survey drawings showing the existing and new levels of the road between the carriageway and the development. You will have to pay all administration, design, supervision and other costs. We will carry out any work which affects the road. For more advice, please phone 020 7641 2642. (I69AA)

- 6 Please contact our Cleansing section on 020 7641 7962 about your arrangements for storing and collecting waste. (I08AA)
- 7 We recommend you speak to the Head of the District Surveyors' Services about the stability and condition of the walls to be preserved. He may ask you to carry out other works to secure the walls. Please phone 020 7641 7240 or 020 7641 7230. (I22AA)
- 8 You must apply for a licence from our Highways Licensing Team if you plan to block the road or pavement during structural work to support the building. Your application will need to show why you cannot support the building from private land. For more advice, please phone 020 7641 2560. (I36AA)
- 9 You are encouraged to join the nationally recognised Considerate Constructors Scheme. This commits those sites registered with the Scheme to be considerate and good neighbours, as well as clean, respectful, safe, environmentally conscious, responsible and accountable. For more information please contact the Considerate Constructors Scheme directly on 0800 783 1423, siteenquiries@ccscheme.org.uk or visit www.ccscheme.org.uk.
- 10 This development has been identified as potentially liable for payment of the Mayor of London's Community Infrastructure Levy (CIL). Responsibility for paying the levy runs with the ownership of the land, unless another party has assumed liability. We will issue a CIL Liability Notice to the landowner or the party that has assumed liability with a copy to the planning applicant as soon as practicable setting out the estimated CIL charge., If you have not already done so you must submit an **Assumption of Liability Form** to ensure that the CIL liability notice is issued to the correct party. This form is available on the planning portal at <http://www.planningportal.gov.uk/planning/applications/howtoapply/whattosubmit/cil> , Further details on the Mayor of London's Community Infrastructure Levy can be found on our website at: <http://www.westminster.gov.uk/services/environment/planning/apply/mayoral-cil/> . **You are reminded that payment of the CIL charge is mandatory and there are strong enforcement powers and penalties for failure to pay.**
- 11 Developing this site is likely to damage archaeological remains. Archaeological work must be carried out in line with condition 9 and 10. Please contact English Heritage's Archaeological Officer on 020 7973 3732 to discuss the work which is necessary. (I66AA)
- 12 You are advised that all illuminated advertisements or high level advertisements require express advertisement consent before they can be displayed. Notwithstanding what is shown on the

Item No.
5

approved drawings this permission does not approve the display of such advertisements.

Please note: the full text for informatives can be found in the Council's Conditions, Reasons & Policies handbook, copies of which can be found in the Committee Room whilst the meeting is in progress, and on the Council's website.

DRAFT DECISION LETTER

Address: 5-9 Great Newport Street, London, WC2H 7JB,

Proposal: Demolition of rear addition to No. 5 Great Newport Street, and internal alterations within listed building at No. 5. Works in association with works at Nos. 6-9 Great Newport Street to carry out partial demolition behind retained front facades, excavation and redevelopment to provide a building comprised of basement, lower ground, ground and six upper floors, terraces, roof plant and alterations to facade, for a new theatre and ancillary facilities at ground floor (part) basement and lower ground floor levels, restaurant (Class A3) on the ground floor and lower ground floors and a 66 bedroom hotel at ground floor (part) and first to sixth floor levels, associated hotel bar and sculpture gallery at part ground floor level.

Plan Nos: Location Plan, 3207_00_207 B, 208 D, 209 B, 210 B, 211 C, 214 A, Existing Front Elevations (unnumbered), 3207_20_101 C, 102 C, 103 C, 104 C, 105 C, 106 C, 107 C, 108 C, 109 D, 110 C, 111 C, 112 C, 113 B, 200 A, 201 E, 202 E, 203 I, 204 G, 205 E, 206 F, 207 E, 208 K, 209 K, 210 H, 211 J, 212 M, 213 M, 214 H, 215 E, 216 N, 218 J, 219 D, 220 C, Design and Access Statement dated April 2012, Design and Access Statement Addendum dated November 2013, Historic Buildings Architect's Report dated April 2008, Heritage Statement dated April 2012, Archaeological Desktop Assessment dated April 2008.

Case Officer: David Dorward

Direct Tel. No. 020 7641 2408

Recommended Condition(s) and Reason(s) or Reason(s) for Refusal:

- 1 The development hereby permitted shall be carried out in accordance with the drawings and other documents listed on this decision letter, and any drawings approved subsequently by the City Council as local planning authority pursuant to any conditions on this decision letter.

Reason:

For the avoidance of doubt and in the interests of proper planning.

- 2 All new work and improvements inside and outside the building must match existing original adjacent work in terms of the choice of materials, method of construction and finished appearance. This applies unless differences are shown on the approved drawings or are required in conditions to this permission. (C27AA)

Reason:

To protect the special architectural or historic interest of this building and to make sure the development contributes to the character and appearance of the Covent Garden Conservation Area. This is as set out in S25 and S28 of Westminster's City Plan: Strategic Policies adopted November 2013 and DES 1 and paras 10.108 to 10.146 of our Unitary Development Plan that we adopted in January 2007. (R27AC)

Item No.
5

- 3 You must apply to us for approval of details of the following parts of the development with detailed drawings at a scale of 1:10 and full size details -

- (i) all new secondary glazing
- (ii) all new doors

You must not start any work on these parts of the development until we have approved what you have sent us.

You must then carry out the work according to these approved details. (C26DB)

Reason:

To protect the special architectural or historic interest of this listed building. This is as set out in S25 and S28 of Westminster's City Plan: Strategic Policies adopted November 2013 and DES 1 of our Unitary Development Plan that we adopted in January 2007, and paragraph 2.3 and 2.4 of our Supplementary Planning Guidance: Repairs and Alterations to Listed Buildings. (R27BC)

- 4 All existing floorboards are to be retained in situ.

Reason:

To protect the special architectural or historic interest of this listed building. This is as set out in S25 and S28 of Westminster's City Plan: Strategic Policies adopted November 2013 and DES 1 of our Unitary Development Plan that we adopted in January 2007, and paragraph 2.3 and 2.4 of our Supplementary Planning Guidance: Repairs and Alterations to Listed Buildings. (R27BC)

- 5 You must apply to us for approval of the following parts of the development:

- 1) A historic paint analysis report and colour samples and drawings annotated to show new decorative schemes for all rooms and the main staircase,
- 2) Details of the scope of paint removal and plasterwork repairs,
- 3) Details of the installation of mechanical and electrical services where they affect historic fabric,
- 4) A method statement and schedule setting out all works of repair and restoration to carpentry, joinery, and plasterwork.

You must not start any work on these parts of the development until we have approved what you have sent us.

You must then carry out the work according to these details.

Reason:

To protect the special architectural or historic interest of this listed building. This is as set out in S25 and S28 of Westminster's City Plan: Strategic Policies adopted November 2013 and DES 1 of our Unitary Development Plan that we adopted in January 2007, and paragraph 2.3 and 2.4 of our Supplementary Planning Guidance: Repairs and Alterations to Listed Buildings. (R27BC)

- 6 **Pre Commencement Condition.** You must apply to us for approval of detailed drawings of the following parts of the development-

Item No.
5

- detailed plans showing the route of the kitchen extract ducts through the building and detailed plans, section and elevation of where where they terminate to the external parts of the building
- detailed plans and sections of the glazed roof to the hotel atrium

You must not start work until we have approved what you have sent us.

You must then carry out the work according to these approved drawings.

Informative(s):

- 1 SUMMARY OF REASONS FOR GRANTING CONDITIONAL LISTED BUILDING CONSENT - In reaching the decision to grant listed building consent with conditions, the City Council has had regard to the relevant policies in the National Planning Policy Framework March 2012, the London Plan July 2011, Westminster's City Plan: Strategic Policies adopted November 2013, and the City of Westminster Unitary Development Plan adopted January 2007, as well as relevant supplementary planning guidance, representations received and all other material considerations.

The City Council decided that the proposed works would not harm the character of this building of special architectural or historic interest.

In reaching this decision the following were of particular relevance:
S25 and S28 of Westminster's City Plan: Strategic Policies and DES 10 including paras 10.130 to 10.146 of the Unitary Development Plan, and paragraph 2.3 and 2.4 of our Supplementary Planning Guidance: Repairs and Alterations to Listed Buildings.

- 2 You will need to contact us again if you want to carry out work on the listed building which is not referred to in your plans. This includes:
 - * any extra work which is necessary after further assessments of the building's condition;
 - * stripping out or structural investigations; and
 - * any work needed to meet the building regulations or other forms of statutory control.

Please quote any 'TP' and 'RN' reference numbers shown on this consent when you send us further documents.

It is a criminal offence to carry out work on a listed building without our consent. Please remind your client, consultants, contractors and subcontractors of the terms and conditions of this consent. (I59AA)

RESOLUTION

4. PLANNING APPLICATIONS

The Strategic Director Built Environment, submitted reports in relation to the following applications for determination by the Sub-Committee, copies of which are included in the register in the custody of the Head of Legal & Democratic Services.

1. 5-9 GREAT NEWPORT STREET, WC2

Demolition of Nos. 6-9 Great Newport Street behind retained front facades and demolition of rear addition to No. 5 Great Newport Street. Excavation and redevelopment to provide a building comprised of lower basement, basement, lower ground, ground and six upper floors, terraces, roof plant and alterations to front facade, providing a new auditorium and ancillary services in the form of a new flexible 322 seat theatre space and arts club venue along with rehearsal studio and ancillary facilities including bars at basement level 1 and ground floor level (*sui generis*), restaurant (Class A3) on the ground floor and part lower ground floors and a 66 bedroom hotel at part ground and first to sixth floor levels (across 5-9 Great Newport Street), associated hotel bar and sculpture gallery at first floor level and outdoor swimming pool, terrace and bar at fifth floor level.

A late representation was received from Michael Lowndes (13 May 2014).

The Planning Officer presenting the application tabled the following revised recommendation on the planning application draft decision letter (additional/revised wording in red italics):

For Sub-Committee's consideration:

1. In the light of the viability report received, does Sub-Committee agree that the enhanced theatre facilities outweigh the normal policy presumption to protect the existing D1 floorspace, the requirement to provide residential floorspace or a financial contribution to the affordable housing fund in lieu of residential floorspace to address the uplift in commercial floorspace? and planning obligations including Crossrail contributions?

2. Subject to 1. above, grant conditional permission subject to the completion of a S106 planning obligation to secure:

a) the provision and retention of a replacement theatre fitted out to shell and core and the potential for the restaurant to be linked to the theatre (the detailed obligations as outlined in the report of the Strategic Director Built Environment).

- b) *the placing of £600,000 into an escrow account to be released to a theatre operator to fund the fit out of the theatre*
- c) *the theatre space to be used for theatrical performances on at least 320 days a year (further details within the legal agreement)*
- d) *to ensure the link between the theatre and restaurant is open before, during and after performances*
- e) *the provision and retention of a publicly accessible curated sculpture gallery within the hotel.*
- f) *S106 monitoring and costs.*

3. *If the agreement has not been completed by 31 July 2014 then:*

a) *The Strategic Director shall consider whether it would be possible and appropriate to issue the permission with additional conditions attached to secure the benefits listed above. If so, the Strategic Director is authorised to determine and issue the decision under Delegated Powers; however, if not*

b) *The Strategic Director shall consider whether the permission should be refused on the grounds that it has not proved possible to complete an agreement within an appropriate timescale, and that the proposals are unacceptable in the absence of the benefits which would have been secured; if so, the Strategic Director is authorised to determine the application and agree appropriate reasons for refusal under Delegated Powers.*

4. *Grant conditional listed building consent.*

5. *Grant conditional conservation area consent.*

6. *Agree the reasons for granting listed building consent and conservation area consent as set out in Informative 1 of the draft decision letters.*

Additional conditions

i) You must provide the access and all additional facilities including accessible toilets and theatre seating for people with disabilities as shown on the approved drawings before you use the building.

ii) {b Pre Commencement Condition}. You must apply to us for approval of detailed drawings of the following parts of the development-

- detailed plans showing the route of the kitchen extract ducts through the building and detailed plans, section and elevation of where where they terminate to the external parts of the building
- detailed plans and sections of the glazed roof to the hotel atrium

You must not start work until we have approved what you have

sent us.

You must then carry out the work according to these approved drawings.

- ii) You must not create any additional useable floorspace within the hotel atrium.

Revised Conditions

- 25 You must apply to us for approval of a Servicing Management Plan, which includes details of how the hotel, restaurant and theatre will be serviced, including details proposing the hours of servicing for each use. You must not occupy the hotel or restaurant until we have approved what you have sent us. Thereafter you must then manage the servicing in accordance with the Servicing Management Plan that we approve, unless we agree an alternative Servicing Management Plan in writing.
- 32 Customers shall not be permitted within the theatre premises before 0800hrs or after 0000hrs daily.

RESOLVED: That the application be deferred to allow the applicants to address the following issues raised by the Sub-Committee:

- (1) The Sub-Committee welcomed the reinstatement of the theatre in principle but noted that failure to secure an acceptable operator was a key issue. Members therefore agreed that, if the City Council were to accept the loss of the existing D1 floorspace and increase in commercial floorspace without any residential uplift, then confirmation of an acceptable operator would be necessary to offer sufficient reassurance that a theatre will be provided.
- (2) The Sub-Committee further agreed that the applicant will need to offer the new theatre at peppercorn rent in order to justify overturning the City Council's normal policy requirements set out in (1) above.
- (3) Members raised concerns regarding the significant proposed increase in the height and bulk of the rear of the building and the detrimental impact upon residents in Sandringham Flats. The Sub-Committee therefore requested that the height and bulk of the proposed extension be addressed.
- (4) Members were largely content with the operating hours detailed in the report and did not agree to the extended hours as requested by the applicant in their late representation dated 13 May 2014. The Sub-Committee requested that the hours of use of the roof top pool be amended to 09:00 – 22:00 hours.

- (5) Members raised further concerns regarding the detail of the draft S106 agreement produced by the applicant, which the Sub-Committee unanimously determined to be insufficiently robust as to protect the interests of the City Council. Members noted that any draft legal agreement must secure provision of the replacement theatre fitted-out to shell and core prior to the occupation of the hotel and restaurant, in addition to the provision and retention of a publicly accessible curated sculpture gallery within the hotel to compensate for the loss of the photographers gallery and to ensure that the £600,000 being offered is only used to fit out the theatre.
- (6) The Sub-Committee also agreed that the applicant must contribute towards S106 construction monitoring costs and pay CiL obligations.

2. 1 CHADWICK STREET, SW1

Demolition of existing buildings and erection of two replacement buildings comprising a seven storey building and a five storey building to provide a total of 44 residential units with associated basement for 27 car parking spaces and 55 cycle parking spaces and mechanical plant, together with associated works including landscaping.

An additional representation was received from Fergus Coleman, WCC Head of Affordable and Private Sector Housing (9 May 2014).

A late representation was received on behalf the applicant (9 May 2014).

The Planning Officer presenting the application tabled the following minor changes to recommendation to add an annual fee of £15,000 for Environmental Inspectorate and subject to no new material issues being raised before the expiry of the consultation period.

For Sub-Committee's consideration:

1. Does the Sub-Committee consider that the offer of 2 x 3 bed affordable rent duplex units at £210 per week in Block B is acceptable given the circumstances of the case?

2. Subject to 1. above, and to no new material issues being raised before the expiry of the consultation period, to grant conditional permission subject to a S106 legal agreement to secure the following:

i) The provision of 2 x 3 bed affordable rent duplex units at £210 per week in Block B to be provided prior to the occupation of the market units;

ii) A parking mitigation payment of £17,000 index linked and payable on

APPENDIX

Item No.
1

CITY OF WESTMINSTER											
PLANNING APPLICATIONS SUB-COMMITTEE	Date 13 May 2014	Classification For General Release									
Report of Strategic Director Built Environment		Wards involved St James's									
Subject of Report	5-9 Great Newport Street, London, WC2H 7JB										
Proposal	Demolition of Nos. 6-9 Great Newport Street behind retained front facades and demolition of rear addition to No. 5 Great Newport Street. Excavation and redevelopment to provide a building comprised of lower basement, basement, lower ground, ground and six upper floors, terraces, roof plant and alterations to front facade, providing a new auditorium and ancillary services in the form of a new flexible 322 seat theatre space and arts club venue along with rehearsal studio and ancillary facilities including bars at basement level 1 and ground floor level (sui generis), restaurant (Class A3) on the ground floor and part lower ground floors and a 68 bedroom hotel at part ground and first to sixth floor levels (across 5-9 Great Newport Street), associated hotel bar and sculpture gallery at first floor level and outdoor swimming pool, terrace and bar at fifth floor level.										
Agent	Turley Associates										
On behalf of	Consolidated Development Ltd										
Registered Number	12/03930/FULL 12/03931/LBC 12/03936/CAC	TP / PP No	TP/5377								
Date of Application	04.04.2012	Date amended/ completed	17.05.2012								
Category of Application	Major										
Historic Building Grade	Grade II Listed Building										
Conservation Area	Covent Garden										
Development Plan Context - London Plan July 2011 - Westminster's City Plan: Strategic Policies 2013 - Unitary Development Plan (UDP) January 2007	Within London Plan Central Activities Zone Within Core Central Activities Zone										
Stress Area	Within West End Stress Area										
Current Licensing Position	<p>The Arts Theatre is currently licensed to be open between 09.00 hours to 00.00 hours. Although the sale of alcohol is restricted to 23.30 hours Mondays to Thursdays and 22.30 hours on Sundays.</p> <p>The existing restaurant known as Salvador and Amanda at 8-9 Great Newport Street is licensed to open between the following hours:</p> <table style="width: 100%; border: none;"> <tr> <td style="padding-left: 20px;">Monday:</td> <td style="padding-left: 20px;">09.00 to 01.30</td> </tr> <tr> <td style="padding-left: 20px;">Tuesday to Thursday</td> <td style="padding-left: 20px;">09.00 to 02.30</td> </tr> <tr> <td style="padding-left: 20px;">Friday to Saturday:</td> <td style="padding-left: 20px;">09.00 to 03.30</td> </tr> <tr> <td style="padding-left: 20px;">Sunday:</td> <td style="padding-left: 20px;">09.00 to 01.00</td> </tr> </table> <p>The restrictions on the sale of alcohol follows the above times but brought forward by half an hour on each day.</p>			Monday:	09.00 to 01.30	Tuesday to Thursday	09.00 to 02.30	Friday to Saturday:	09.00 to 03.30	Sunday:	09.00 to 01.00
Monday:	09.00 to 01.30										
Tuesday to Thursday	09.00 to 02.30										
Friday to Saturday:	09.00 to 03.30										
Sunday:	09.00 to 01.00										



Item No.
1

1. RECOMMENDATION

For Sub-Committee's consideration:

1. Subject to confirmation of viability, does Sub-Committee agree that the enhanced theatre facilities outweigh the normal policy presumption to protect the existing D1 floorspace, the requirement to provide residential floorspace or a financial contribution to the affordable housing fund in lieu of residential floorspace to address the uplift in commercial floorspace, and planning obligations including Crossrail contributions?

2. Subject to 1. above, grant conditional permission subject to the completion of a S106 planning obligation to secure:

- a) the provision and retention of a theatre and the potential for the restaurant to be linked to the theatre (the detailed obligations as outlined in the report of the Strategic Director Built Environment).
- b) the provision and retention of a publicly accessible curated sculpture gallery within the hotel.
- c) S106 monitoring and costs.

3. If the agreement has not been completed by 31 July 2014 then:

- a) The Strategic Director shall consider whether it would be possible and appropriate to issue the permission with additional conditions attached to secure the benefits listed above. If so, the Strategic Director is authorised to determine and issue the decision under Delegated Powers; however, if not
- b) The Strategic Director shall consider whether the permission should be refused on the grounds that it has not proved possible to complete an agreement within an appropriate timescale, and that the proposals are unacceptable in the absence of the benefits which would have been secured; if so, the Strategic Director is authorised to determine the application and agree appropriate reasons for refusal under Delegated Powers.

4. Grant conditional listed building consent.

5. Grant conditional conservation area consent.

6. Agree the reasons for granting listed building consent and conservation area consent as set out in Informative 1 of the draft decision letters.

X

2. SUMMARY

The application site is comprised of a row of buildings between 5 and 9 Great Newport Street. No. 5 is Grade II listed and the entire site lies within the Covent Garden Conservation Area, the Core Central Activities Zone and the West End Stress Area.

The buildings on the site range from between four and six storeys with basements, and they contain a variety of uses including the Arts Theatre Club (sui generis), the former site of the 'Photographers Gallery' (Class D1), restaurant/bar (mixed A3 and A4), offices and a language school. Permission and consents are sought for the demolition behind the retained facades of 6-9 Great Newport Street and demolition of the rear addition to No. 5 Great Newport Street. It is then proposed to excavate three storeys below 6-9 Great Newport Street and to redevelop the site to provide the following:

- a building comprised of lower basement, basement, lower ground, ground and six upper floors, terraces, roof plant and alterations to front façade;
- provision of a new auditorium and back of house facilities in the form of a new 322 seat theatre space along with rehearsal studio and ancillary bars at ground floor (part) and basement level.1;
- restaurant (Class A3) on the ground floor and part lower ground floor;
- a 66 bedroom hotel at ground floor (part) and first to sixth floor levels, associated hotel bar and sculpture gallery at first floor level and outdoor swimming pool, terrace and bar at fifth floor level.

The key issues for consideration are:

- The acceptability of the proposals in land use terms.
- The quality and long term viability of the proposed replacement theatre.
- The impact of the proposals on the character and appearance of the conservation area and the listed buildings at 4 and 5 Great Newport Street.
- The impact of the external alterations on the amenities of neighbouring residents.
- The impact of the proposed uses on residential amenity and character and function of the conservation area.
- The impact of the servicing arrangements on the surrounding highway network.

Subject to Sub-Committee's views on the acceptability of the proposals in land use terms, and the suitability of the proposed replacement theatre, the applications are considered acceptable in highways, amenity and design terms and are in accordance with City Plan and Unitary Development Plan (UDP) policies.

3. CONSULTATIONS

CONSULTATION RESPONSES TO INITIALLY SUBMITTED SCHEME (MAY 2012)

ENGLISH HERITAGE

No formal objection to the proposals and authority has been given to the local planning authority to determine the applications as they see fit. However, concern has been raised with regard to the extension at the rear in terms of the visual impact they will have on the setting of the rear of the Grade II listed buildings at Nos. 4 and 5 Great Newport Street.

THE THEATRES TRUST

Supports the scheme in principle and welcomes the alterations proposed from the previously withdrawn applications in 2008 and 2009 including increased capacity and further back of house facilities. However, they suggest that a further independent advisory review exercise should be carried out in tandem with theatre professionals to gather further advice on configurations, sightlines and usability. They also suggest that detailed theatre signage should

Item No.
1

also be proposed and/or conditioned.

SAVE LONDON'S THEATRES

Any response to be reported verbally.

COUNCIL FOR BRITISH ARCHAEOLOGY

Generally supports the proposal but would ask for conditions securing an archaeological report given the extent of excavation proposed.

SOCIETY FOR THE PROTECTION OF ANCIENT BUILDINGS

Regrets the possible impact on the legibility of the rear of the listed building at No. 5 Great Newport Street, and has concerns about the deep piles alongside the party wall of No. 5.

VICTORIAN SOCIETY

Any response to be reported verbally.

GEORGIAN SOCIETY

Any response to be reported verbally.

20TH CENTURY SOCIETY

Any response to be reported verbally.

ANCIENT MONUMENTS SOCIETY

Any response to be reported verbally.

LONDON BOROUGH OF CAMDEN

Acknowledgement letter received, but no further comments provided.

COVENT GARDEN COMMUNITY ASSOCIATION

Design looks attractive, but concerns raised about daylight and sunlight impact to Sandringham Flats, amenity impact of proposed roof top pool and bar, and concerns about lack of S106 contributions for viability reasons.

COVENT GARDEN AREA TRUST

No comment.

LONDON UNDERGROUND

No objection subject to conditions requiring detailed information (design and method statements) to demonstrate that excavation proposed will not impact upon London Underground tunnels or structures.

BUILDING CONTROL

No objection. Proposed methodology for basement excavation looks acceptable in principle.

HIGHWAYS PLANNING MANAGER

No objection, but concerns raised about on street servicing. A condition requiring a robust Servicing Management Plan or Operational Management Plan will be required.

ENVIRONMENTAL HEALTH

No objection subject to standard conditions and a condition requiring a supplementary acoustic report with regards to mechanical plant proposed.

CLEANSING MANAGER

No objection subject to condition securing the waste and recycling stores as proposed.

ADVERTISEMENT/SITE NOTICE: Yes

X

ADJOINING OWNERS/OCCUPIERS AND OTHER REPRESENTATIONS
No. Consulted: 201; Total No. of Replies: 17 (from 14 different addresses);

Design:

- Added height will have a major effect on this short and narrow street.
- Development will ruin views.

Amenity:

- Loss of sunlight/daylight to Sandringham Flats.
- Impact of open air pool and bar at roof level on residential amenity.
- Overlooking from roof bar area - threatens enjoyment of private roof gardens on Sandringham Flats.
- Future amenity problems arising from restaurant/bar areas.

Land Use:

- Hotel and restaurant uses not required in this area - no demand.

Other:

- Noise pollution and disturbance during the development.
- Concerns about piling.
- Increase in traffic.

CONSULTATION RESPONSES FROM AMENDED SCHEME - EXTENDED BASEMENT TO FACILITATE LARGER THEATRE SPACE AND OTHER ALTERATIONS

ENGLISH HERITAGE ARCHAEOLOGY

Any response to be reported verbally.

THEATRES TRUST

Supports the scheme and welcomes the enhancements to the theatre space following Theatre Consultant's suggested amendments. Most notably there is now a rehearsal room which has been designed to operate as both a studio theatre or function room with significant income generating opportunities, and will have a wider benefit to the West End as there is a notable shortage of rehearsal spaces in the area. They also advise that an Operational Management Plan should be secured by condition, and a further condition to secure a record of the Arts Theatre both photographically and with plans which are then lodged with the Resources Centre at the Theatres Trust.

LONDON UNDERGROUND

No objection subject to conditions requiring detailed information (design and method statements) to demonstrate that excavation proposed will not impact upon London Underground tunnels or structures.

BUILDING CONTROL

Any response to be reported verbally

COVENT GARDEN AREA TRUST

No comment.

COVENT GARDEN COMMUNITY ASSOCIATION

Revised proposals are an improvement. However, concerns remain regarding lack of consultation with Sandringham Flats residents, mechanical plant has not been specified, servicing and deliveries to hotel should be limited to be between 08.00 and 22.00, conditions should limit use of roof top terrace and pool to 22.00, impact of increased basement excavation has not been assessed, the revised plans do not show where theatre docks doors

~~X~~

Item No.
1

will be, and finally concerns are raised about the impact on daylight and sunlight to the occupiers within Sandringham Flats.

ADJOINING OWNERS/OCCUPIERS AND OTHER REPRESENTATIONS

No. Consulted: 201; Total No. of Replies: 21.

21 objections (from 18 different addresses) received relating to the following:

Design:

- Loss of heritage asset, i.e. demolition of theatre.

Amenity:

- Loss of daylight and sunlight to flats, roof terraces and courtyards all associated with Sandringham Flats.
- Increased noise nuisance from plant machinery.
- Noise nuisance from pool and terrace.
- Impact on amenity from more intensive use not acceptable within stress area.

Theatre:

- History of existing theatre must be protected.
- Concerns that theatre will operate as a cabaret/nightclub venue and a suitable replacement theatre will not be achieved.
- Absence of fly-tower in replacement theatre will massively impact upon ability of theatre to stage productions and many theatre productions will no longer consider the theatre as a potential viable space. It will result in smaller scale theatre such as burlesque, cabaret and music.
- Flexible use of space/auditorium is not compatible with daily theatre use.
- The Arts Theatre has recently acquired rehearsal studio space elsewhere in the building and therefore this benefit is no longer applicable.
- There are enough flexible spaces available in London for conferences, stand up comedy, etc, but not enough small scale viable theatres such as this one.
- The current Arts Theatre offers a valuable resource as a space to show mid scale work and has relationships with many institutions to ensure a diverse and supportive programme of new theatre work.
- The loss of the current theatre would be a tragedy.

Other:

- Obliteration of views.
- Long programme of works will affect quality of life.
- Concerns about impact of basement excavation.
- Do not agree that the current theatre is not viable.

4. BACKGROUND INFORMATION

4.1 The Application Site and Surroundings

The buildings at 5-9 Great Newport Street lie on the north side of the road and occupy a significant part of this side of the road given the streets relatively short length.

The existing buildings at Nos. 6-9 above the theatre are a maze of circulation routes, staircases and access points which have developed organically over time. This has resulted in an unattractive street level frontage comprised of several doorways including fire escape doors, servicing entrances and the various entrances to the commercial uses above.

The site is flanked to the west by No. 10-11 Great Newport Street which was recently granted

Item No.
1

permission to convert from offices to residential flats with a rear extension. To the east beyond the listed building on the site at No. 5, is another listed building at No. 4, which is currently in use as a bar known as 'Verve'.

To the north and west of the site at the rear is a development of housing known as Sandringham Flats. Directly to the north and the rear of the site is a very large 15-16 storey office building known as Orion House which fronts onto West Street.

Great Newport Street itself consists mainly of commercial uses including several food and drink uses at ground floor level with offices or other commercial uses above. There are however, a few residential flats on the upper floors of the buildings directly opposite the site and as stated earlier permission has recently been granted for 15 new flats at 10-11 Great Newport Street. A further nine flats have also recently been approved at 12 Great Newport Street. These permissions are yet to be implemented.

The site is within the Covent Garden Conservation Area and is also within the Core Central Activities Zone and the West End Stress Area.

4.2 Relevant History

On the 16 October 1989 permission was granted in respect of 6-9 Great Newport Street for the demolition of the existing premises and a redevelopment to provide theatre, ground floors retail and offices above. This permission was never implemented.

An application similar to that which is now being considered was submitted in January 2008, but was later withdrawn pending further discussions with English Heritage, theatre groups and other interested parties.

In 2010 an application related to the listed building at No. 5 Great Newport Street was submitted for the use of the ground and first floor as mixed cultural space with offices on the remaining floors. This application was refused on the grounds that it would result in the loss of the gallery/retail use (Photographer's Gallery) which was on site at that time.

5. THE PROPOSAL

The current applications propose the demolition of Nos. 6-9 Great Newport Street behind retained facades to the street. The site would then be redeveloped to provide a replacement 322 seat theatre and ancillary spaces including a large rehearsal/studio space with a capacity of approximately 100. A new restaurant internally linked to the theatre reception space would also be located at ground and part lower ground floor. The remainder of the site would become a 66 bedroom hotel, with its main entrance being via a refurbished No. 5 Great Newport Street. The hotel would then spread across the upper floors across the rest of the site and would include a publicly accessible sculpture gallery within the main hotel bar area at first floor level, and there would be a further bar at fifth floor level, which opens out onto a terrace with a swimming pool in front of the proposed set back roof extension.

A detailed financial viability assessment has been carried out which sets out that the costs involved with this proposal make it impossible for the applicants to make any financial contributions to any planning obligations required for a development of this size.

At the time of writing, officers were still waiting for findings of the City Council's independently appointed valuation consultant. Their findings will be reported to Sub-Committee.

~~14~~

6. DETAILED CONSIDERATIONS

6.1 Land Use

6.1.1 Existing land uses

(i) Theatre – Arts Theatre

The existing theatre has operated since 1927 when it was set up as a club for theatre enthusiasts which combined a performance space with drinking and dining facilities. It has continued to operate in a similar manner until the current day and has seating for approximately 320. It has a premises license which covers the sale of alcohol, hot food after 22.00 and the performance of plays, live music, film and recorded music. In planning terms it is considered a sui generis use.

(ii) No. 5 Great Newport Street

Previously this property was occupied by The Photographer's Gallery (Class D1); however, this has since moved to a larger premises at 16-18 Ramilles Street, W1. This space has subsequently been taken over by the Future Gallery at ground and lower ground floor and is used as an events and exhibition space. The upper floors are currently used by a number of small business as office space. An enforcement investigation is currently open into the unauthorised use of this building.

(iii) Avalon Language School and Offices

The language school provides English language courses to students from across the world and it occupies several of the upper floors at Nos. 6-9 Great Newport Street. This was granted a temporary personal permission which expired in September 2008, after which it was conditioned to revert to its previous lawful use as B1 offices. There is also some generic office space across the upper floors much of which is currently vacant.

(iv) Restaurant at No. 9 Great Newport Street

The restaurant at No. 9 is currently open until 02.00 and 03.00 on the weekends, and occupies ground and basement levels.

(v) Retail Unit at 8 Great Newport Street

There is a comic book shop which operates from the ground floor. However, this site was also previously used by the Photographers Gallery. It was their original gallery space prior to their expansion into No. 5 Great Newport Street at which point they occupied two sites on the same street. Whilst a small portion of the site (64m²) was used for retail, this is considered to have been ancillary to the main gallery (D1) use. The Photographers Gallery left Great Newport Street in 2010 and subsequently a comic book shop known as 'Orbital Comics' has moved into No. 8, although there is no record of planning permission being granted for a change of use to Class A1 retail.

Item No.
1

6.1.2 Existing and Proposed Land Uses

Land Use	Existing floorspace (m2)	Proposed floorspace (m2)	Change
Theatre (sui generis)	1,684	2,150	+466
Social/Community (D1)	969	0	-969
Restaurant (A3)	536	617	+81
Offices and Language School	986	0	-986
Hotel (C1)	0	4,172 (including 114m2 sculpture gallery)	+4,172
Shared back of house/plant floorspace	-	608	+608
Total	4,155	7,547	+3,392

(The above table is based on assumed lawful uses, not actual uses)

6.1.3 Assessment

Proposed Theatre and Restaurant

The proposed replacement theatre is at the heart of this redevelopment and the judgement of whether the proposed replacement theatre is both acceptable and deliverable is a fundamental consideration.

The applicants are seeking to provide a new 'destination' West End venue which ideally would combine a dining experience alongside a theatre experience. A large part of the ground floor frontage would be given over to the restaurant, with a narrower entrance to the theatre reception and box office than that which the Arts Theatre currently enjoys.

The possible negative impact of this on the visibility/viability of the theatre is being partly addressed through a scheme of highly visible signage akin to the character of West End theatres. A further simple high level painted sign is proposed for the flank wall of the building to increase its presence in the surrounding area. An Informative reminding the applicants that advertisement consent is required for the adverts proposed is recommended.

i) Detailed Theatre Assessment

Several objections have been received from theatre goers and producers alike who regularly visit the current Arts Theatre or who have put on productions at the venue. A common theme amongst these objections is that the current theatre is small scale and provides a unique setting for putting on a certain type of production that would not be feasible at the other larger and more prominent West End venues. It provides an intimate setting and allows for a diverse and supportive range of theatre work, and its loss, as well as its heritage value would be detrimental to London's theatre scene as a whole. A number of objectors have also commented that the new theatre would not have a fly tower, which would prevent a large number of productions from even considering it as a venue.

~~16~~

Throughout the application there has been some confusion as to whether or not the existing theatre has a fly tower; indeed the Theatres Trusts' comments seem to indicate that there is not one. However, following a site visit it can be confirmed that there is a working fly tower within the existing theatre, which will not be reprovided in the proposed scheme.

Notwithstanding this, the applicants have sought to demonstrate that the lack of a fly tower will not impact upon the viability of the theatre, and that the proposed theatre layout will provide a more flexible and viable space. A 'performance consultant' was also engaged by the applicants to provide detailed advice on the design and specification of the proposed replacement theatre.

Subsequently and further to some concerns being raised by officers, the applicants then appointed a specialist theatre consultant, who advised the applicants to make a number of alterations to their proposals. They have now submitted a final detailed assessment which strongly commends the revised scheme.

In summary, they report that the new theatre can be sustainable and viable without a fly tower because of the small scale nature of the theatre. The design changes include a greater height above the stage of no less than 8.3 metres which will allow for conventional scenery used by smaller scale touring shows.

The revised proposals also now include a large rehearsal studio of 120m² beneath the main auditorium. Such a large rehearsal space is highly sought after in the West End, and the opportunity to let out such a space increases the viability of the new theatre. It is also envisaged that this could operate as a much smaller scale intimate performance space with enough room for approximately 100 seats.

In summary, the applicants consultant details the following points as benefits in the redesign over the existing theatre offer –

- Introduction of 120m² rehearsal studio/additional performance space.
- Improved circulation space particularly upon entering the stalls from the ground floor foyer.
- Improved auditorium seating with better audience/actor relationship.
- Additional dressing room accommodation.
- Increased wardrobe space.
- Staff locker rooms provided
- Improved stage depth.
- Increased height under stage.
- Enlarged stage basement to accommodate storage, and many other ancillary areas.

The Theatres Trust has commented on the revised proposals and is supportive. They state that the revised proposals result in a theatre which is more flexible and capable of offering more to both audiences and performers, but also enables the theatre to potentially generate more revenue and be more sustainable. They also offer support to the improved auditorium design, the studio theatre/rehearsal space, the potential for the restaurant to work in conjunction with the theatre and that the issue of external signage has now been addressed appropriately.

Notwithstanding these revisions concerns have been raised by consultees (including the Theatres Trust) and officers that the flexible nature and design of the proposed theatre may pose a risk that theatre groups would find it difficult or unattractive to put on shows there, and that other non-theatrical uses could be more profitable to the operator. However, following detailed negotiations, a comprehensive legal agreement has been drafted to ensure that the number of operational theatre days every year would be a minimum of 320.

~~X~~

Item No.
1

The Theatres Trust has commented that they are encouraged by this, but have also requested that an Operational Management Plan be requested via a condition, and that they be consulted on this.

On this point alone, the draft legal agreement secures the use of the auditorium for live theatre performances for a minimum of 320 days per year. It also makes provisions for this space along with the studio theatre/rehearsal space to be used for a number of other uses in addition to this.

Therefore, it is not considered necessary to request an Operational Management Plan relating specifically to the theatres operation in addition to what is set out in the legal agreement. This would be an unnecessary duplication. Instead an Operational Management Plan will be required to address the amenity impacts of the application as a whole.

To ensure that a replacement theatre is actually provided following the demolition of the existing one, the draft legal agreement also includes clauses which set out when the phases of the redevelopment need to be carried out by and how these costs are borne out. This includes the following:

- Not to Occupy the Hotel until the Theatre Space has been constructed to Shell & Core
- On completion of the Theatre Space to Shell and Core a sum of £600,000 to be placed in an escrow account (to be administered by the Freeholder's solicitor) for the funding of the Theatre Space fit-out as specified. This sum to be payable to the Theatre Operator on its signing of a contract with fit-out contractors.

City Plan Policy S22 and UDP Policies TACE 5 and TACE 6 protect existing theatres and arts and cultural uses. TACE 6 (B) states that in those very exceptional circumstances where it is necessary to redevelop a theatre, a suitable replacement will be required to be provided within a stated period.

The theatre in its current state continues to showcase small to medium scale productions and alongside the cocktail bar, which operates from its front lounge/foyer area, it appears to remain a viable operation. Therefore, whilst it is not considered that the redevelopment of the theatre is strictly necessary, it is evident that the current theatre does require substantial investment to bring it up to a decent standard.

Policy TACE 6 goes on to state that a replacement theatre should improve accessibility, visibility, performance and operational areas, provide front and back of house facilities and provide rehearsal space. The applicants have put forward a proposal which they believe meets these objectives, and which can only be achieved through the demolition of the existing theatre and the provision of a completely new facility.

The replacement theatre would of course be subject to appropriate conditions to control capacity, hours of operation, and appropriate sound proofing arrangements, given the proximity of possible new residential accommodation along Great Newport Street.

ii) Detailed Restaurant Assessment

The applicants intend to include a sliding or removable partition between the theatre reception/bar and the restaurant, which can be pulled back prior to and during performances to enhance the feeling of a destination space and to link the operation of the restaurant and theatre.

However, at this stage the applicants do not have a operator on board for either the restaurant or the theatre and therefore as the restaurant could feasibly be managed and run by a

Item No.
1

separate operator to the theatre, it is considered necessary to build this part of the proposal into the legal agreement.

This would state that the moveable partition between the restaurant and the entrance to the theatre space on the ground floor would be retracted and kept open for a period of 90 minutes in advance of the start of all live theatre evening and matinee performances and for a further period of 45 minutes following curtain down.

The restaurant itself would occupy 617m². As this is over 500m² and within the designated West End Stress Area UDP Policy TACE 10 will apply. This policy states that enlarged restaurants such as this would only be acceptable in exceptional circumstances.

Given that the existing restaurant (which is to be lost as a result of the proposed redevelopment) is also over 500m² this policy can be applied with a degree of flexibility given that the increase in A3 floorspace only amounts to 81m².

In addition to the minor increase in size, the existing restaurant is not subject to any planning conditions or controls. Granting permission for a new restaurant would allow the City Council to impose conditions on capacity and opening hours which would give the City Council control over its operation and potentially reduce any adverse effects on residential amenity when compared with the existing. Furthermore, the proposed restaurants' link with the replacement theatre would enhance the viability of the theatre which itself makes an important contribution to Central London activity.

With suitable conditions in place the proposed restaurant is considered to comply with Policy TACE 10 and S24 and is considered acceptable.

Loss of Offices and Language School

There are no current planning policies to protect Class B1 office accommodation. The Language School is also seen as a commercial use and the loss of this alongside regular office floorspace is considered acceptable in land use terms.

Loss of Class D1 Social/Community floorspace

The buildings at No. 5 and No. 8 Great Newport Street housed the 'Photographer's Gallery', which is classed as a social and community use (Class D1). Under City Plan Policy 'S34 Social and Community Infrastructure' it is expected that all social and community floorspace will be protected except where existing provision is being reconfigured, upgraded or is being re-located in order to improve services and meet identified needs. In this instance the applicant has argued that as the 'Photographer's Gallery' has successfully relocated to a larger premises within Westminster at Ramilies Street, W1, the aspirations of this policy have been met. Furthermore, they also argue that only a small proportion of the floorspace occupied by the Photographer's Gallery was actual gallery space (198m² of 969m²), and the rest was offices, storage, a small cafe and ancillary retail space.

This latter argument is not persuasive, as gallery uses often have ancillary spaces for storage, offices, etc. However, the fact that the Photographers Gallery has relocated within Westminster is undeniable and whilst the Ramilies Street site does not form part of this application it is recognised that the Class D1 occupier has vacated this site.

Notwithstanding this however, the lawful use remains Class D1 and it must be demonstrated that no other alternative social/community user wishes to use the site. The applicants have not provided evidence to show if the site has been marketed for social/community use.

Instead, in an attempt to address the loss of social/community floorspace on the site, the

~~X~~

Item No.
1

applicants are proposing a curated sculpture gallery at first floor level within the proposed hotel. This would be publicly accessible and visible from within the hotel bar area. The applicants have suggested that they would afford a local art institute opportunities to display works.

Notwithstanding this, it is considered that the loss of the Class D1 social/community floorspace from this site is contrary to City Plan Policies S21 and S34 and UDP Policy SOC 1 (D), and the views of the Sub-Committee are sought on this matter in light of the other benefits of the scheme.

Proposed Hotel and Sculpture Gallery

Policy S23 in the City Plan states that new hotels will be directed to areas included the Core Central Activities Zone, in which this site is located, and should be directed towards streets which do not have a predominantly residential character.

Currently Great Newport Street has a strong commercial character, although planning permission has recently been granted for nine new residential units at 12 Great Newport Street and 15 new residential units at 10-11 Great Newport Street. These permissions are yet to be implemented.

UDP Policy TAGE 2 states that planning permission for new hotels within the CAZ will be granted where there are no adverse environmental and traffic effects and there are adequate facilities for the setting down and picking up of visitors by coaches and for taxi's serving the hotel.

Although no designated areas for picking up and setting down visitors are proposed, the Highways Planning Manager is satisfied that the proposed hotel can be accommodated in this location without any significant adverse impacts on the local highways network. The hotel is a mid ranged size hotel with 66 bedrooms, which is unlikely to receive visitors on coaches, and the frequency of taxi drops off and pickups is unlikely to cause an adverse impact on the highway.

Furthermore, given the high PTAL rating (6b) of the site and its proximity with several bus routes along Charing Cross Road, London Underground stations at Leicester Square and Covent Garden and the mainline station at Charing Cross, a hotel of this size in this location is considered acceptable in land use terms. A further analysis of the impact of the hotel on local residential amenity is contained with the amenity and transportation sections later in this report.

6.1.4 Mixed use policies

The proposals result in an uplift of commercial floorspace of 2784m² on site. As the site falls within the CAZ UDP Policy CENT 3 applies. This states that where appropriate and practical, increases in commercial floorspace will require the equivalent provision of self-contained residential accommodation on site, and where this is not practical it should be provided offsite. Following this the cascade approach of this policy then states that other uses which contribute to the CAZ should be provided instead and failing that a financial contribution to the City Council's affordable housing fund should be sought.

The applicants have set out a case as to why residential on site would not be practical or suitable. They cite the following reasons –

- The retained facades place constraints on access to the buildings.
- The design constraints of the listed building, particularly in terms of providing additional cores.

- Given the location there would be a lack of good quality external amenity space.
- Several units would be single aspect due to the buildings orientation.

Whilst some of these points have some validity, it is perhaps more pertinent to note that the provision of an enhanced and viable theatre is fundamental to the success of these proposals, and the provision of several residential units in close proximity and/or directly above the new theatre may bring these uses into conflict, which in turn may impact upon the long term viability of the theatre. It is therefore accepted that it would not be practical to provide residential onsite.

The applicants have also stated that they do not have any buildings in the proximity of the site which could be used to provide 2,784m² of residential floorspace.

The provision of an enhanced theatre space could be considered to go some way to addressing the part of the policy which states that other uses which contribute to the CAZ should be provided. However, given that the replacement theatre is required by other City Plan/UDP policies this is not considered to fully meet the policy requirements and therefore a payment in-lieu to the affordable housing fund would be required.

This has been calculated at £4,006,361.

The applicants have provided a viability report which they say demonstrates that the extremely high costs of building the theatre and the development as a whole do not allow them to make a financial contribution.

The findings of the City Council appointed viability consultant are not yet available but will be reported verbally to Sub-Committee.

6.1.5 Conclusion

The proposed theatre, restaurant and hotel are, on their own merits, considered acceptable uses, however, Sub-Committee's views are sought as to whether the provision of an enhanced theatre space outweighs the items which are contrary to policy; namely the loss of D1 floorspace and the failure to provide any onsite residential floorspace (or a payment in-lieu) given the uplift in commercial floorspace.

6.2 Townscape and Design

6.2.1 Existing Buildings

No. 5 Great Newport Street is Grade II listed and was originally conceived as a late 17th century terraced house. It is comprised of three storeys, mansard roof and basement. It has been successively refronted during its history, most recently in the 1950s when the current black polished tile frontage with metal casement windows were added. The rear was altered and extended in the 1980s. Its interior whilst altered does retain features of historic interest, most notably the original staircase, historic chimneypieces, cornicing, panelling, architraves and the original plan form on the upper storeys.

No. 6-7 Great Newport Street is a five storey unlisted building constructed in 1895. The front elevation is red brick and can loosely said to be in a Queen Anne Revival style. The neighbouring building at 8-9 Great Newport Street is also five storeys. It was built in c.1900 and is also of red brick. Although its facade is relatively plain it does contain some stone banding and window lintels, and makes a positive contribution to the street and the surrounding conservation area.

The rear parts of these building have been subject to significant levels of alteration over their

histories. Consequently they are of little architectural merit.

6.2.2 Demolition and Façade retention

The applications propose to demolish the unlisted building at Nos. 6, 7, 8 and 9 Great Newport Street behind their retained façades. In the light of the information provided by the applicants about the buildings and the lack of an adopted Conservation Area Audit for the Covent Garden Conservation Area it is considered that the key contribution of these buildings is their front façades. In applying Policy DES 9 of the UDP, and the guidance of the NPPF to the current proposal, the degree of demolition proposed (with the Great Newport Street facades retained) is considered acceptable.

6.2.3 Height and Bulk

The application proposes to increase the height of the rebuilt buildings by one storey to the front portion of the site when compared with the existing. Following negotiations with officers this extra storey has been pushed back to the point where it is only partially visible from street level. The flank wall has also now been redesigned to be constructed of brick rather than glass. These elements of the scheme are now considered acceptable in design terms.

The most contentious element of the proposals is the significant increase in height and bulk to the rear of the site. The existing rear additions at Nos. 5, 6, 7, 8 and 9 Great Newport Street are all of limited quality, have suffered a number of unsympathetic additions, and are poorly maintained. They also vary in height from four storeys to the rear of Nos. 8 and 9, to two and three storeys at the rear of Nos. 5, 6 and 7. Therefore the full potential of the site is not utilised by the buildings in their current form.

The proposed extensions will comprise a block rising to six storeys (ground plus five) across the majority of the site. However, the site's context includes a 15 to 16 storey office tower known as Orion House to the north and Meridian House to the east which is comprised of six storeys, the rear facade of which faces the application site but contains no windows. Views across the site are therefore very limited because of its surroundings and the rear of this city block is completely enclosed.

It is acknowledged that the extensions and increased bulk will be visible in private views from the upper floor windows and communal terraces at Sandringham Flats. However, given the context of the surroundings, and that the existing unlisted buildings' rear extensions do not positively contribute to the character and appearance of the conservation area, it is not considered that refusal could be sustained on the grounds that the proposal would have a detrimental impact on the character and appearance of the conservation area.

6.2.4 Detailed design, Shopfronts and Signage

The detailed design of the development is clearly modern with a largely glazed atrium and lift shaft set well back towards the middle of the site. The proposed roof extension is also modern with a largely glazed front facade.

Notwithstanding this, these elements are all mostly invisible from the street, and there are only limited private views onto the site. Given that the façades are being retained it is considered that along with standard conditions requiring details of the proposed shopfronts and other architectural details, the proposals are considered acceptable in design terms.

It is proposed to mark the entrance to the theatre with a canopy. Fascia and canopy signage and a high level painted sign are also proposed. Whilst the architectural details of the canopy will be secured through a condition, any high level signage or illuminated advertisements will require express advertisement consent. A suitable Informative advising the applicants of this

is recommended.

6.2.5 Listed building alterations

The work to remove the existing extension to the rear of the listed building at No. 5 Great Newport Street is acceptable. This is a modern addition to the building which was erected in the 1980s and is of no heritage value.

Concerns have been raised by both English Heritage and the Society for the Protection of Ancient Buildings with regard to the impact that the development will have on the setting of the rear of this listed building and the neighbouring listed building at No. 4 Great Newport Street.

The proposed alterations and extensions on land to the rear of the listed buildings (Nos. 4 and 5 Great Newport Street) will affect their setting, but noting that the context includes a tower block, the proximity of the new building is not so close to the listed buildings as to harm their setting. While it would be desirable not to have such a large development so close to the listed buildings and for its detailed design to be less stridently modern, in its current form the development is considered neutral in heritage asset terms with regard to its impact on the listed buildings.

The internal alterations to the building to facilitate its use as a hotel are not contentious and will maintain the special interest of the listed building.

Subject to conditions requiring specific detailed drawings and a method statement detailing the restoration proposed, the applications are acceptable in historic building terms.

6.2.6 Archaeology

It is noted that the sites falls within an Area of Special Archaeological Importance as defined by Westminster UDP known as 'Lundenwic and Thorney Island'.

The applicants have acknowledged this and have submitted an Archaeological Desktop Assessment of the site, particularly given that it is proposed to excavate three storeys below ground level.

The submitted report indicates that there is a high potential for Saxon and post-medieval remains to be found on this site. English Heritage Archaeology has been consulted and any feedback received will be reported verbally to Sub-Committee.

In any event, given the conclusions of the submitted desktop assessment it is considered prudent to impose conditions requiring method statements and a written scheme of investigation to be carried out in relation to the necessary archaeological work.

6.2.7 Design conclusions

In conclusion therefore, it is considered that the proposal is considered to have a neutral affect on the character and appearance of the unlisted buildings, the setting of the listed buildings and the surrounding conservation area and will maintain the special interest of the listed building. Therefore the proposals are considered acceptable in design terms and adhere to City Plan Policies S25 and S28 and UDP Policies DES 1, DES 5, DES 6, DES 9 and DES 10.

6.3 Amenity

6.3.1 Daylight and Sunlight and Sense of Enclosure

Policy ENV13 seeks to protect existing premises, particularly residential, from a material loss

Item No.
1

of daylight and sunlight as a result of new development.

Objectors are concerned about the potential loss of daylight and sunlight as a result of the proposed increase in height and bulk particularly to the rear of the site and the impact upon residents within Sandringham Flats.

These windows have views across the site, although they are not directly behind the application site and are instead to the side and some distance away from the nearest part of the development. The applicants have undertaken a daylight assessment in accordance with the Building Research Establishment (BRE) guidelines. The windows included in the assessment are those in Sandringham Flats and also across the road at 16-18 Great Newport Street which contains residential properties on the upper floors. The report concludes that there will be no additional material impact on daylight and sunlight received by the majority of residential windows. Where there are instances of changes to daylight in excess of the BRE guidelines, these occur where the existing light levels are so low already, that any reduction would show as being high in percentage terms but would not be noticeable to the occupant.

The increase in bulk arising from the extensions at the rear is fairly significant. However, given the significant distance to the windows within Sandringham Flats, it is not considered that there would be an unacceptable increase in the sense of enclosure to habitable rooms as a result of this proposal.

Despite the objections received on these grounds, for the above reasons it is not considered that they can be upheld as sustainable reasons for refusal.

Orion House, the large office block to the rear of the site would have its daylight levels compromised at lower levels and its external terrace at approximately third floor level would also be significantly overshadowed by the proposed increase in bulk. However, the occupants of commercial buildings are not afforded the same protection to their amenities as residential occupiers and a reason for refusal could not be sustained on these grounds.

6.3.2 Impact of hotel

Several objections have been received with regards to the proposed roof top pool and associated terrace on the hotel. Further to initial objections to this part of the scheme the pool has been relocated from the very top of the building so that it sits in front of the proposed set back roof extension. This would shield those residents in Sandringham Flats from any overlooking from this terrace and would also mitigate most of the noise associated with the use of the pool and terrace. Notwithstanding this there are residential properties opposite the site on Great Newport Street and permission has recently been granted for residential flats next door at Nos. 10-11.

Therefore it is considered necessary and reasonable to impose conditions relating to the use of the pool and external terrace, particularly in relation to its hours of use. The site is located within the West End Stress Area and given the proximity of residential properties, hours of 09.00 – 23.00 are considered acceptable.

The hotel itself is mid range in size with 66 bedrooms, and is unlikely to cause an adverse impact on residential amenity subject to conditions controlling the roof terrace, other bar areas and opening hours to non-hotel residents.

Subject to these conditions the proposed hotel use can be considered acceptable in amenity terms.

Item No.
1

6.3.3 Impact of theatre

The proposed theatre replaces a theatre of a similar size. The only intensification of this use is the introduction of the rehearsal/studio space which if used for performances could attract up to 100 visitors. This is only a small increase and given that these performances could not take place at the same time as performances in the main auditorium this is not considered to cause an unacceptable intensification of the use.

Furthermore, any restrictions on this additional space could affect the long term viability of the theatre.

6.3.4 Impact of restaurant

As set out in the assessment of the proposed land uses earlier in the report, it is considered that the proposed restaurant is likely to bring about some improvements in amenity terms. This is because the existing restaurant is not subject to any planning control or conditions and the City Council as the local planning authority are now able to impose conditions on the new restaurant. These conditions will limit the number of covers to 100 and will set a terminal hour of midnight Monday-Thursday and 00.30 on Fridays, Saturday and Sundays. Furthermore, an Operational Management Plan will be conditioned to ensure that access and egress to the restaurant is managed to mitigate any disturbance to local residential amenity.

6.4 Transportation/Servicing/Parking

The Highways Planning Manager is satisfied that the proposal will not have a significant impact on on-street parking in the local area due to the high level of public transport accessibility and its location within a controlled parking zone.

However, concerns have been raised with regards to the servicing and objectors have raised some concerns that proposed uses and will result in increased pressure being placed on existing highways network and parking in the area. City Plan Policy S42 and UDP Policy TRANS 20 both require adequate off street servicing provision, but in this instance it is proposed to service the development from on street. This is likely to interrupt pedestrian flows and therefore the servicing will need to be carefully managed. This will need to include details on how the arrival of vehicles will be managed to ensure that Great Newport Street is not congested by numerous servicing vehicles arriving at similar times.

It is considered that this can be adequately dealt with a detailed and robust Servicing Management Plan and it is not considered that the servicing of the site from on street could be sustained as a reason for refusal.

No cycle parking is proposed across the site. However, given the unusual nature of the site and its layout it is clear that there are no obvious locations for accessible cycle storage at ground floor level.

The proposals also make reference to a new 'dropped kerb' to the front of the hotel. The purpose of this is unclear, but in any event it is unlikely that the Highway Authority would install a dropped kerb in this location given that it is not a crossing point.

6.5 Economic Considerations

The economic benefits of the scheme are welcomed; the application is subject to a viability assessment as outlined elsewhere in this report.

Item No.
1

6.6 Other UDP/Westminster Policy Considerations

None relevant.

6.7 London Plan

The proposal does not raise strategic issues.

6.8 Planning Obligations

A financial Viability Assessment has been submitted which sets out the case as to why the costs of this proposal are so prohibitive that planning obligations in the form of financial contributions would render the scheme unviable. Previously the City Council has appointed independent viability consultants to assess this, and they have twice before concurred with the applicants consultants.

Given the length of time this application has been in planning, a further instruction has been given to independent consultants to assess the schemes current costs given current market conditions. This report is not available at the time of writing but will be reported to Sub-Committee.

If it were possible for the applicants to provide planning obligations they would be expected to provide the following given the uplift in commercial floorspace of 2,784m² -

- The equivalent in residential floorspace on site or offsite or a payment in-lieu to the City Council's affordable housing fund of £4,008,361
- Public realm contribution of £186,528
- Crossrail contribution of £261,782

The S106 legal agreement should secure arrangements with regards to the proposed replacement theatre, restaurant and gallery space within the hotel. These can be summarised as follows -

- Occupation of the hotel only on the completion of the theatre to shell and core.
- Occupation of the restaurant only on the completion of the fit out of the theatre to accommodate performance.
- The setting aside of £600,000 (index-linked) to fund the fit out of the theatre including the seating.
- The use of the theatre space for theatrical performances for a minimum of 320 days a year.
- Securing the link between the restaurant and the theatre at ground floor level.
- The securing of a sculpture gallery within the hotel which will be open to the public.
- Monitoring costs

6.9 Environmental Assessment Including Sustainability and Biodiversity Issues

The proposal will achieve a BREEAM rating of 'Outstanding' which would be achieved by the inclusion of Combined Heat and Power (CHP) into the redevelopment and some minor energy efficiency savings equating to 6%. Overall this would equate to carbon savings of in excess of 40% over Part L of the Building Regulations. Whilst no on site renewable technologies are proposed, given the large carbon savings generated through the CHP it is considered that the proposal is acceptable in sustainability terms.

Conditions ensuring that the proposed development meets BREEAM 'Outstanding' are recommended.

6.10 Conclusion

It is considered that the proposal is considered acceptable in design, amenity, transportation and sustainability. However, the loss of D1 floorspace amounting to over 900m², and the lack of on site residential provision or a payment-in-lieu would ordinarily be considered unacceptable in land use policy terms.

The suitable replacement of a theatre on this site is of utmost importance in terms of providing arts/cultural facilities in Westminster in the context of adopted Policies TACE 5, TACE 6 and S22. This is supported by the Theatres Trust. Officers also consider that the proposed replacement theatre would offer an enhanced facility over the existing theatre. Therefore, the Sub-Committee's views are sought as to whether the provision of this new theatre and its ancillary parts outweigh those aspects of the scheme which are not policy compliant.

BACKGROUND PAPERS

CONSULTATION COMMENTS ON ORIGINAL SCHEME

1. Application forms
2. Letters from English Heritage (x3) dated 10.09.2012
3. Letter from The Theatres Trust dated 13.09.2012
4. Email from the Council of British Archaeology dated 10.07.2012
5. Letter from the Society for the Protection of Ancient Buildings dated 25.06.2012
6. Letter from the London Borough of Camden dated 28.06.2012
7. Letter from Covent Garden Community Association dated 19.06.2012
8. Letter from Covent Garden Area Trust dated 19.06.2012
9. Letter from London Underground dated 11.06.2012
10. Memorandum from Building Control dated 14.06.2012
11. Memorandum from Highways Planning Manager dated 29.08.2012
12. Memorandum from Environmental Health dated 29.06.2012
13. Memorandum from Cleansing Manager dated 11.06.2012
14. Letter from the occupier of [REDACTED] dated 25.07.2012
15. Letter from the occupier of [REDACTED] dated 24.07.2012
16. Letter from the occupier of [REDACTED] dated 25.07.2012
17. Letter from occupier of unknown local address dated 21.06.2012
18. Letter from the occupier of [REDACTED] dated 20.06.2012
19. Letter from the occupier of [REDACTED] dated 20.06.2012
20. Letter from the occupier of [REDACTED] dated 19.06.2012
21. Letter from person of unknown address dated 03.06.2012
22. Letter from the occupier of [REDACTED] dated 12.06.2012
23. Letter from the occupier of [REDACTED] dated 17.06.2012
24. Letter from the occupier of [REDACTED] dated 12.06.2012
25. Letter from the occupier of [REDACTED] dated 13.06.2012
26. Letter from the occupier of [REDACTED] dated 04.06.2012 and 06.06.2012
27. Letter from the occupier of [REDACTED] dated 02.06.2012
28. Letters from AKA Planning Consultants on behalf of the residents and owners of [REDACTED] dated 20.07.2012 and 30.01.2013

CONSULTATION COMMENTS ON REVISED SCHEME

1. Letter from The Theatres Trust dated 04.03.2014
2. Letter from London Underground dated 04.02.2014
3. Letter from Covent Garden Community Association dated 11.04.2014